



UltraTemp[®] Heat Pump



AHRI Performance Certified



Installation and User's Guide



IMPORTANT SAFETY INSTRUCTIONS
READ AND FOLLOW ALL INSTRUCTIONS
SAVE THESE INSTRUCTIONS

Customer Service

If you have questions about ordering Pentair Water Pool and Spa® ("Pentair") replacement parts, and pool products, please use the following contact information:

Customer Service (8 A.M. to 4:30 P.M. — Eastern and Pacific Times)

Phone: (800) 831-7133

Fax: (800) 284-4151

Technical Support

Sanford, North Carolina (8 A.M. to 4:30 P.M. — Eastern Time)

Phone: (919) 566-8000

Fax: (919) 566-8920

Moorpark, California (8 A.M. to 4:30 P.M. — Pacific Time)

Phone: (805) 553-5000

Fax: (805) 553-5515

Web site

visit www.pentairpool.com or www.staritepool.com to find information about Pentair products

© 2011 Pentair Water Pool and Spa, Inc. All rights reserved.

This document is subject to change without notice.

1620 Hawkins Ave., Sanford, NC 27330 • (800) 831-7133 • (919) 566-8000

10951 West Los Angeles Ave., Moorpark, CA 93021 • (800) 831-7133 • (805) 553-5000

Trademarks and Disclaimers: UltraTemp®, IntelliTouch®, EasyTouch®, Eco Select™ and Pentair Water Pool and Spa® are trademarks and/or registered trademarks of Pentair Water Pool and Spa, Inc. in the United States and/or countries. Unless noted, names and brands of others that may be used in this document are not used to indicate an affiliation or endorsement between the proprietors of these names and brands and Pentair Water Pool and Spa, Inc. Those names and brands may be the trademarks or registered trademarks of those parties or others.

Contents

Important Warning and Safety Instructions.....	iii
Section 1: Introduction.....	1
Heat Pump Overview	1
General Features	2
Section 2: Installation.....	3
Installation.....	3
Materials Needed for Installation	3
UltraTemp® Heat Pump Dimensions	4
Location	4
Clearances.....	5
Roof Run-off.....	5
Equipment Pad.....	5
Drainage and Condensation	6
Lawn Sprinklers	6
Anchor Clamp Installation.....	6
Water Connections.....	7
Standard Plumbing	7
Water Connections (Quick Connect).....	8
Automatic Flow Control Valve	8
Multiple Unit Installation	9
Heat Pump, Heater and/or Solar Combination.....	9
Multiple Heat Pump Connections.....	10
Electrical Connections	11
General Information	11
Main Power	11
Bonding.....	11
Remote Operation.....	12
Relay Remote Controls.....	12
Connecting the Heat Pump to IntelliTouch® or EasyTouch® Load Center via the Heat Pump Spade Terminals.....	13
Connecting the Heat Pump to IntelliTouch® or EasyTouch® Load Center via RS-485 Connector.....	14
Connecting the Heat Pump Control Board to IntelliTouch® or EasyTouch® via RS-485 Connector.....	14
Pin Configuration for the Heat Pump Control Board to IntelliTouch®	15
Connecting the IntelliTouch® or EasyTouch® to the Heat Pump	15
Water Pressure Switch Adjustment.....	16

Section 3: Operating the Heat Pump	17
Initial Start-up Precautions.....	17
Heat Pump Control Panel Overview	18
Control Panel Layout.....	18
Control Panel Operation.....	19
Timers and Delays	23
Control Panel Menu Tree Screens	24
Control Panel Menu Screens	25
Operator Setup Menu Tree Screens	27
Operator Setup Menu Screens	28
Locking the Control Panel.....	29
Defrost Cycle	29
AutoSet	30
Control Panel Alarm Messages	31
Heat Pump Wiring Diagram – (Single Phase – 50/60 Hz)	32
Heat Pump Wiring Diagram – (Three Phase – 60 Hz).....	33
Heat Pump Wiring Diagram – (Three Phase – 50 Hz).....	34
AutoSet Contactor to Mechanical Timer Wiring Example	35
Section 4: General Maintenance	36
Water Chemistry	36
Winterizing	36
Spring Start-Up.....	37
Inspection and Service	37
Owner Inspection.....	37
Professional Maintenance and Service.....	38
Section 5: Troubleshooting	39
Temperature Resistance Chart Table	42
Ambient/Water Flow Table for Professional Maintenance and Service	43
Section 6: Replacement Parts	44
Illustrated Parts (UltraTemp®).....	44
Replacement Parts List (UltraTemp®).....	45

IMPORTANT WARNING AND SAFETY INSTRUCTIONS



Important Notice:

This guide provides installation and operation instructions for the UltraTemp® Heat Pump. Consult Pentair with any questions regarding this equipment.

Attention Installer: This guide contains important information about the installation, operation and safe use of this product. This information should be given to the owner and/or operator of this equipment after installation or left on or near the heat pump.

Attention User: This manual contains important information that will help you in operating and maintaining this heat pump. Please retain it for future reference.



WARNING — Before installing this product, read and follow all warning notices and instructions which are included. Failure to follow safety warnings and instructions can result in severe injury, death, or property damage. Call (800) 831-7133 for additional free copies of these instructions.

Codes and Standards

UltraTemp® heat pumps are listed by ETL as complying with the latest edition of the “UL Standard for Safety for Heating and Cooling Equipment”, UL 1995 and CSA C22.2 No. 236.

All Pentair heat pumps must be installed in accordance with the local building and installation codes as per the utility or authority having jurisdiction. All local codes take precedence over national codes. In the absence of local codes, refer to the latest edition of the National Electric Code (NEC) in the United States and the Canadian Electric Code (CEC) in Canada for installation.



DANGER — **Risk of electrical shock or electrocution.**



The electrical supply to this product must be installed by a licensed or certified electrician in accordance with the National Electrical Code and all applicable local codes and ordinances. Improper installation will create an electrical hazard which could result in death or serious injury to pool or spa users, installers, or others due to electrical shock, and may also cause damage to property. Read and follow the specific instructions inside this guide.



WARNING — To reduce the risk of injury, do not permit children to use this product unless they are closely supervised at all times.



WARNING — For units intended for use in other than single-family dwellings, a clearly labeled emergency switch shall be provided as part of the installation. The switch shall be readily accessible to the occupants and shall be installed at least 5 feet [1.52 m] away, adjacent to, and within sight of the unit.

IMPORTANT WARNING AND SAFETY INSTRUCTIONS

Consumer Information and Safety

The UltraTemp® series of heat pumps are designed and manufactured to provide safe and reliable service when installed, operated and maintained according to the information in this manual and the installation codes referred to in later sections. Throughout the manual, safety warnings and cautions are identified by the “” symbol. Be sure to read and comply with all of the warnings and cautions.

 **WARNING** — The U.S. Consumer Product Safety Commission warns that elevated water temperature can be hazardous. See below for water temperature guidelines before setting temperature.

 **WARNING** — The following “Safety Rules for Hot Tubs” recommended by the U.S. Consumer Product Safety Commission should be observed when using the spa.

1. Spa or hot tub water temperatures should never exceed 104° F. [40° C.]. A temperature of 100° F. [38° C.] is considered safe for a healthy adult. Special caution is suggested for young children. Prolonged immersion in hot water can induce hyperthermia.
2. Drinking of alcoholic beverages before or during spa or hot tub use can cause drowsiness which could lead to unconsciousness and subsequently result in drowning.
3. **Pregnant women beware!** Soaking in water above 100° F. [38° C.] can cause fetal damage during the first three months of pregnancy (which may result in the birth of a brain-damaged or deformed child). Pregnant women should stick to the 100° F. [38° C.] maximum rule.
4. Before entering the spa or hot tub, the user should check the water temperature with an accurate thermometer. Spa or hot tub thermostats may err in regulating water temperatures.
5. Persons with a medical history of heart disease, circulatory problems, diabetes or blood pressure problems should obtain their physician’s advice before using spas or hot tubs.
6. Persons taking medication which induce drowsiness, such as tranquilizers, antihistamines or anticoagulants should not use spas or hot tubs.

Hyperthermia occurs when the internal temperature of the body reaches a level several degrees above normal body temperature of 98.6° F. [37° C.]. The symptoms of hyperthermia include: drowsiness, lethargy, dizziness, fainting, and an increase in the internal temperature of the body.

The effects of hyperthermia include:

1. Unawareness of impending danger.
2. Failure to perceive heat.
3. Failure to recognize the need to leave the spa.
4. Physical inability to exit the spa.
5. Fetal damage in pregnant women.
6. Unconsciousness resulting in danger of drowning.

Warranty Information

Heat pumps are sold with a limited factory warranty. Details are specified on the warranty card. Make all warranty claims to an authorized Pentair dealer or directly to the factory. Claims must include the heat pump serial number and model (this information can be found on the rating plate), installation date, and name of the installer. Shipping costs are not included in the warranty coverage. This warranty does not cover damage caused by improper assembly, installation, operation, improper water chemistry balancing or other chemical abuse, or improper sanitation application, winterizing, field modification, or failure to earth bond and properly ground the unit. Any changes to the heat pump, evaporator, heat exchanger, wiring, or improper installation may void the warranty.

IMPORTANT WARNING AND SAFETY INSTRUCTIONS

Swimming Pool Energy Saving Tips

It is important to note that a heat pump will not heat a pool as fast as a large gas or electric pool heater. If the pool water is allowed to cool significantly, it may take several days to return to the desired swimming temperature. For weekend use, it is *more economical* to maintain the pool water temperature at or near your desired swimming temperature. If you do *not* plan to use your pool for a prolonged period, then you might choose to turn the heat pump completely off or decrease the temperature setting of the control several degrees to minimize energy consumption.

Pentair offers the following recommendations to help conserve energy and minimize the cost of operating your heat pump without sacrificing comfort.

1. The American Red Cross recommends a maximum water temperature of 78° F. [25° C.]. Use an accurate pool thermometer. A difference of 4° F. [2° C.], between 78° F. and 82° F. [26° C. and 28° C.], will significantly increase energy consumption.
2. Carefully monitor the water temperature of your pool in the summertime. You can reduce heat pump usage due to warmer air temperatures.
3. During the winter or when on vacation for longer than a week, turn off the heat pump.
4. Find the proper setting on the heat pump temperature control and use the Keypad Lock function to discourage further adjustments.
5. Where possible, shelter the pool from prevailing winds with well-trimmed hedges or other landscaping, cabanas, or fencing.
6. Pentair recommends the use of a pool cover. Besides providing a valuable safety feature, a pool cover will reduce heat loss, conserve chemicals, and reduce the load on filter systems.

Technical Information

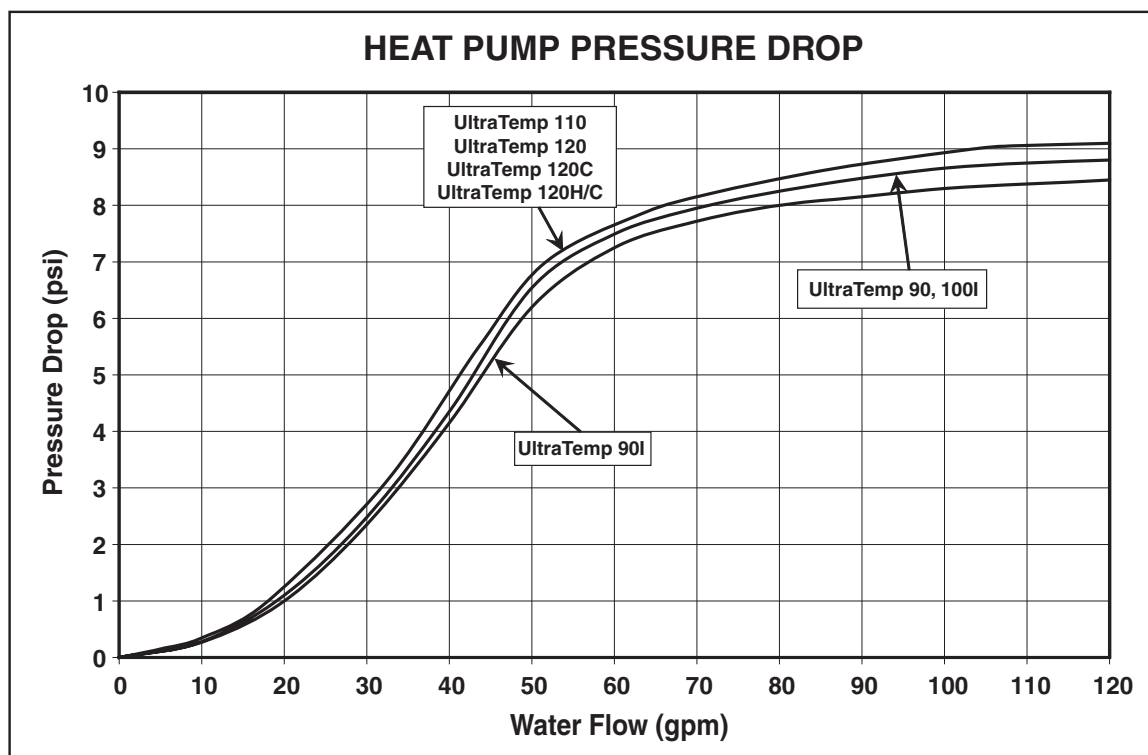

IMPORTANT WARNING AND SAFETY INSTRUCTIONS

General Installation Information

1. Installation and service must be performed by a qualified installer or service agency, and must conform to all national, state, and local codes.
2. UltraTemp® heat pumps get electrical power from an external source and provide a dual electronic thermostat control system for pool/spa combinations or preheat convenience.
3. This heat pump is specifically designed for heating fresh water swimming pools and spas. Do not use it as a general service heater. Consult your dealer for the appropriate Pentair products for these applications.

General Specifications

Installation Location Certified for use:

OUTDOOR USE ONLY. Failure to provide the proper clearances outlined on page 5 will lower the performance of the heat pump and void the warranty.

Water Pipe/Heater Connection — Plastic 2" PVC (Unions included)

Flow Rate

Maximum 100 gpm [380 lpm]

Minimum 30 gpm [110 lpm]

Maximum Working Water Pressure 50 psi

Electrical Supply – Voltage Requirements:

Models	UltraTemp®						
	90	110	120	120 H/C	120C	100I	90I
Voltage/Phase/Hz	208-230/1/60	208-230/1/60	208-230/1/60	208-230/1/60	208-230/3/60	230/1/50	380-400/3/50
Min. Circuit Ampacity (Amp)	40	42	42	42	35	42	18
Recommended Fuse Size	50	50	50	50	50	50	30
Max Fuse Breaker Size	60	70	70	70	60	60	40
Compressor/Fan Motor/System RLA	31/2/33	32/2/34	32/2/34	32/2/34	26/2/28	32/2/34	12/1/13
Compressor/Fan Motor/System LRA	178/4/182	148/4/152	185/4/189	185/4/189	190/4/194	130/4/134	87/3/90
Compressor/Fan Motor/System MCC	49/NA/NA	50/NA/NA	50/NA/NA	50/NA/NA	39/NA/NA	50/NA/NA	19/NA/NA
Capacity (Btu/h) 80A-80RH-80W *	90,000	108,000	125,000	125,000	125,000	102,000	85,000
COP 80A-80RH-80W *	5.8	5.8	5.5	5.4	5.7	5.9	5.7
Power Input (KW) 80A-80RH-80W*	4.5	5.5	6.7	6.8	6.4	5.1	4.4
Current (Amp) 80A-80RH-80W*	21	25	30	31	19	25	9
Capacity (Btu/h) 80A-62RH-80W **	84,000	101,000	117,000	117,000	115,000	96,000	81,000
COP 80A-62RH-80W **	5.5	5.5	5.3	5.2	5.3	5.6	5.4
Power Input (KW) 80A-62RH-80W**	4.5	5.4	6.5	6.6	6.2	5	4.4
Current (Amp) 80A-62RH-80W**	20	25	29	30	18	24	9
Capacity (Btu/h) 50A-63RH-80W ***	60,000	72,000	82,000	82,000	81,000	67,000	56,000
COP 50A-63RH-80W ***	4	4	4	4	4	4	4
Power Input (KW) 50A-63RH-80W***	4.2	5.3	6	6	5.9	4.9	4.1
Current (Amp) 50A-63RH-80W***	19	24	27	27	17	24	9
Weight (lbs) ****	250	270	270	278	280	280	250
Shipping Size (LxWxH) incl. Pallet	43"x34"x39"	43"x34"x51"	43"x34"x51"	43"x34"x51"	43"x34"x51"	43"x34"x47"	43"x34"x39"

* 80A-80RH-80W: 80° F Air Temp, 80% RH, 80° F Water Inlet Temp.

** 80A-62RH-80W: 80° F Air Temp, 62% RH, 80° F Water Inlet Temp.

*** 50A-63RH-80W: 50° F Air Temp, 63% RH, 80° F Water Inlet Temp.

**** Add 50 lbs. for Pallet and Packaging.

COP = Coefficient of Performance

Section 1

Introduction

Overview

Your Pentair heat pump will provide you with years of heated pool enjoyment. Heat pumps operate by taking heat from the surrounding air and transferring it into the water. The warmer the air and the more humidity in the air, the more latent heat is available for heating your pool. With a properly sized heat pump for your pool, the heat pump should raise your pool on average 1° F. per hour depending on air temperature, humidity, and water temperature. The ideal or rated condition for the heat pump is 80° F air temperature, 80% relative humidity, and 80° F water temperature. As conditions decrease from 80/80/80, the heat pump performance will decrease slightly.

Heat Pumps are best utilized to maintain a set water temperature; they are not intended to provide instant or fast heating. It is not reasonable to expect a heat pump to perform like a gas heater which has a much higher BTU output and faster response. Additionally, gas heaters are not dependent on environmental conditions. Swimming pool heat pumps are very similar to home heating and air conditioning heat pumps and therefore should be treated similarly.

Proper operation and use of the heat pump is to set it at your desired temperature and leave it. Your heat pump will turn on and off automatically to maintain your desired temperature much like your home HVAC unit. To take advantage of the sun's energy, operate your heat pump during the heat of the day. Your heat pump will still operate when the temperature drops at night, but the output will be decreased.

It is acceptable to shut the heat pump off and not use it for extended periods of time. When you have a need to heat your pool, please plan accordingly since it may take the heat pump days to heat your pool back to your desired temperature, depending on your pool temperature and environmental conditions.



General Features

- Dual digital thermostats offer precise temperature control to maintain the desired separate water temperatures in pool/spa combinations without overheating or wasting energy.
- Long-life corrosion resistant composite plastic cabinet stands up to severe climates and pool chemicals.
- 100% pure titanium heat exchanger assures corrosion-free performance for extra long life.
- Self-diagnostic control panel monitors and troubleshoots heat pump operations to ensure safe, dependable operation.
- LCD control board displays an intuitive menu-driven read out with easy to follow full word messages- no more codes.
- Autoset (time clock over-ride) feature monitors water temperature and turns the water circulation pump on and off as needed to maintain desired pool temperatures.
- Automatic defrost feature senses refrigerant temperature and prevents the heat pump from freezing, allowing the heat pump to operate at even lower temperatures.
- Compatible with all automated control packages.
- Thermostatic expansion valve (TXV) controls refrigerant flow for optimum efficiency and BTU output over a wider operating range.
- Each unit undergoes a finishing process to ensure corrosion resistance and long life.
- Elevated base pan for positive drainage of condensation.
- 2-inch plumbing connections for easy installation.
- Separate isolated electrical compartment prevents internal corrosion, extends heater life.
- RS485 communication compatible with IntelliTouch® and EasyTouch® control systems.
- Highest efficiency available, meets or exceeds existing codes and standards.
- Adjustable timer allows to set the heat pump to run for a predetermined time. Incremental by 10 minutes to a maximum of 99 hours.
- Ability to display text in Spanish.
- ETL listed for safe operation.
- AHRI Performance Certified.

Section 2

Installation

The following general information describes how to install the UltraTemp® heat pump.

Installation

Only a qualified service person should install the heat pump. **Before installing this product, read and follow all warning notices and instructions on pages iii-vi.**

Materials needed for Installation

The following items are needed and are to be supplied by the installer for *all* heat pump installations:

1. Plumbing connections (2 inch).
2. Level surface for proper drainage.
3. Suitable electrical supply line. See rating plate on unit for electrical specifications. A junction box is not needed at the heat pump; connections are made inside of the heat pump electrical compartment. Conduit may be attached directly to the heat pump jacket.
4. Electric cutout switch that will interrupt all power to the unit. This switch *must* be within line of sight of the heat pump.
5. Watertight conduit to run the electrical supply line.

Note: **We recommend installing isolation valves on the inlet and outlet water connections for ease of serviceability.**

UltraTemp® Heat Pump Dimensions

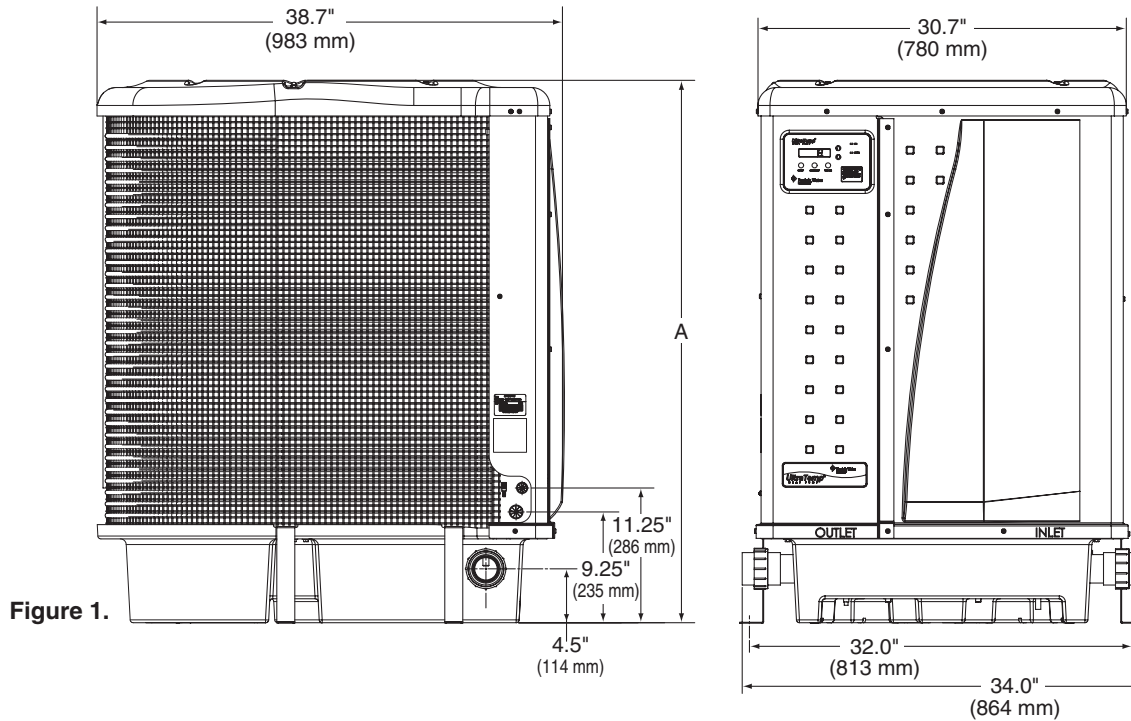

Figure 1.

	MODEL # / ULTRATEMP®						
	90	100	120	120 H/C	120C	100I	90I
Dimension "A"	33.5" (851 mm)	45.5" (1156 mm)	45.5" (1156 mm)	45.5" (1156 mm)	45.5" (1156 mm)	41.5" (1054 mm)	33.5" (851 mm)

Correct installation is required to assure safe operation. The requirements for Pentair heat pumps include the following:

- Dimensions for critical connections.
- Field assembly (if required).
- Appropriate site location and clearances. (See pages 4-5).
- Proper electrical wiring. (See pages vi and 11, 32-34).
- Adequate water flow. (See page vi).

This manual provides the information needed to meet these requirements. Review all application and installation procedures completely before continuing the installation.

Location

CAUTION — When pool equipment is located below the pool surface, a leak from any component can cause large scale water loss or flooding. Pentair Water Pool and Spa, Inc. cannot be responsible for such water loss or flooding which may cause damage to the product.

Avoid placing the heat pump in locations where it can cause damage by water or condensate leakage. If this is not possible, provide a suitable drain pan to catch and divert any leakage.

Clearances

All criteria given in the following sections reflect minimum clearances. However, each installation must also be evaluated, taking into account the prevailing local conditions such as proximity and height of walls, and proximity to public access areas.

The heat pump must be placed to provide clearances on all sides for maintenance and inspection.

1. At least 24 in. [610 mm] access must be available in the front and 12 in. [30.5 mm] on all the other sides of the heat pump for service and proper air flow, see [Figure 2](#). (Manufacturer's recommendation).
2. If the heat pump is to be installed under a cover or under a vertical overhang, the unit must have a minimum of five (5) feet [1520 mm] clearance from the top of the heat pump. (Manufacturer's recommendation).
3. Install a minimum of five (5) feet [1.52 m] from the inside wall of the pool or spa unless the heat pump is separated from the pool or spa by a five (5) foot high solid fence or other permanent barrier. Canadian installations require a minimum of three (3) meters from pool water.

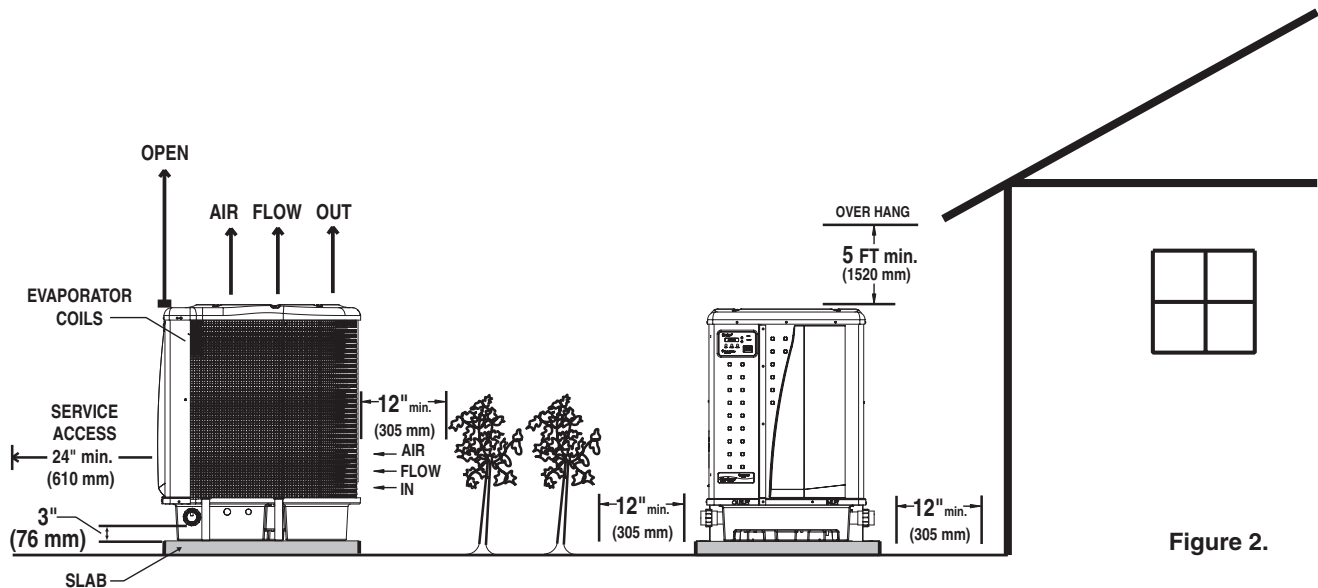

Figure 2.

Roof Run-off

Make sure the heat pump is not located where large amounts of water may run-off from a roof into the unit. Sharp sloping roofs without gutters will allow massive amounts of rain water, mixed with debris from the roof to be forced through the unit, see [Figure 2](#). A gutter or down spout may be needed to protect the heat pump.

Equipment Pad

Place the heat pump on a flat slightly pitched surface, such as a concrete or fabricated slab (pad). This allows proper drainage of condensation and rain water from the base of the unit. If possible, the pad should be placed at the same level or slightly higher than the filter system equipment pad.

NOTE: Ensure that the pad is pitched not more than 1/4 in. per foot toward the compressor end (front) of the heat pump. Pitch slab from back to front 1/4 in. per foot maximum and level from side to side.

Drainage and Condensation

Condensation will occur from the evaporator coil while the unit is running and drain at a steady rate, usually three to five gallons per hour, depending upon ambient air temperature and humidity. The more humid the ambient conditions, the more condensation will be produced. The bottom of the unit acts as a tray to catch rainwater and condensation. Keep the drain holes, located on the bottom pan of the base of the unit, clear of debris.

Lawn Sprinklers

Make sure there are *absolutely no sprinkler heads near the heater* that will in any way spray on or into the heater. **Sprinkler damage is not covered under the warranty agreement.**

Make sure that they're a sufficient distance away so that normal winds will not carry the mist to the heater. If your filtering system area has plants that need water, use a trickle type irrigation sprinkler instead of the broadcast type.

The heater is designed to handle the wettest weather conditions that are typical of rain and humidity, etc. Sprinkler heads force high pressure water into the unit from the side at an odd angle. Most sprinkler systems are connected to a well system.

Most well water is high in minerals, sulphur and other aggressive contaminants. These contaminants will leave a build up on the evaporator coils and electronics causing corrosion and hamper the efficiency. If you are located within 15 miles of the coast, salt may also be in the well water.



Figure 3.

Anchor Clamp(s) Installation

In Florida, building codes require that the heat pump be anchored to the equipment pad or platform to withstand high wind pressures created during hurricanes.

This heat pump is provided with anchor clamps designed to hold the unit to the equipment pad in high wind conditions. Installation of the anchor clamps is recommended in all installations. Installation of the anchor clamps is required in Florida (See Florida Building Code 301.13).

To install the anchor clamps:

1. Be sure that the heat pump is in its permanent location on the equipment pad.
2. Remove the anchor clamps from the installation and instruction package.

Note: Bolts and bolt anchors are not included with the heat pump. The installer must provide 1/4" x 1-3/8" stainless steel anchor bolts and the appropriate size concrete anchor to mount the clamp to the equipment pad.

3. Place the clamps at the base of the heat pump in the 4 locations indicated in Figure 4, (2 in. undercut [notched area] on either side).
4. Fit the hook of each clamp over the lip on the base panel of the heat pump. The hook should fit between the lip of the base panel and the evaporator coil guard, see Figure 5.
5. Mark the position of the hole in each clamp on the equipment pad.

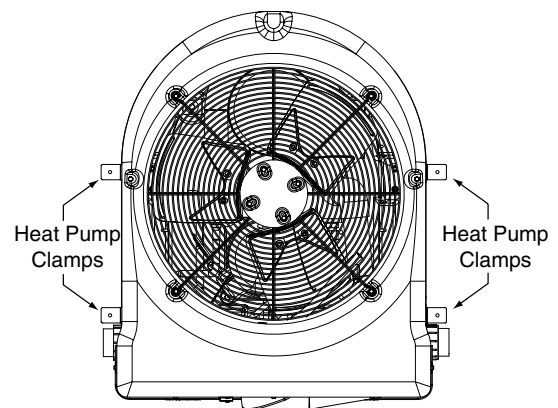

Figure 4.

Anchor Clamp(s) Installation, continued

6. Use a masonry drill bit and drill a hole in the cement with a diameter as determined by the concrete anchor, at each of the marks on the equipment pad. The hole should be approximately 1½ in. deep.
7. Insert a bolt anchor into each of the holes. Be sure the anchors are set completely into the holes
8. Position the anchor clamps so that the holes in the clamps are over the bolt anchors. Be sure that the clamp hooks are over the lip of the heat pump base, see [Figure 5](#).
9. Insert an anchor bolt through each clamp into the anchor and tighten to secure the clamp and heat pump to the equipment pad.

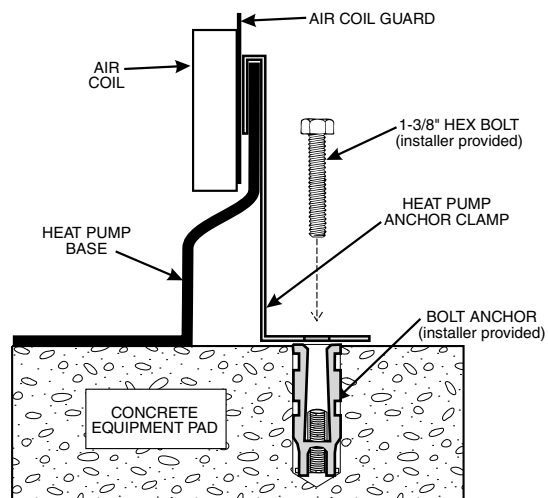

Figure 5.

Water Connections

Plumbing layout

[Figure 6](#) illustrates the standard plumbing layout with a single heat pump unit. Follow the diagram from right to left, the plumbing sequence is as follows:

Pool > Skimmer and Main Drain > Pool Pump > Filter > Heat Pump > Chlorinator > Pool

Note: For normal installations, do not install a shut-off valve or any kind of variable restriction in the water piping between the heat pump outlet and the pool/spa.

The heat pump must be protected from back-siphoning of water. Be sure to provide an optional manual bypass valve between the pool and the heat pump outlet to protect from back-siphoning.

Arrangement of pool system components (other than [Figure 6](#) and following diagrams) can affect the operation of the heat pump's water pressure switch. Location of the heat pump above or below the pool water surface can also affect operation of the switch.

In general, the pressure switch can be adjusted to accommodate this effect if the heat pump water connections are no more than six (6) feet below the pool water surface or no more than fifteen (15) feet above it. See instructions for pressure switch adjustment ([page 16](#)) in the heat pump start-up section of this manual for more information. If the heat pump is installed outside of this range, an external pressure switch may need to be installed in the plumbing upstream of the heat pump. Call the Pentair Heat Pump Technical Service department at (800) 831-7133 for details.

Be advised that when pool equipment is located below the pool surface a leak can result in large-scale water loss or flooding. Pentair cannot be responsible for such water loss or flooding or the damage caused by either occurrence.

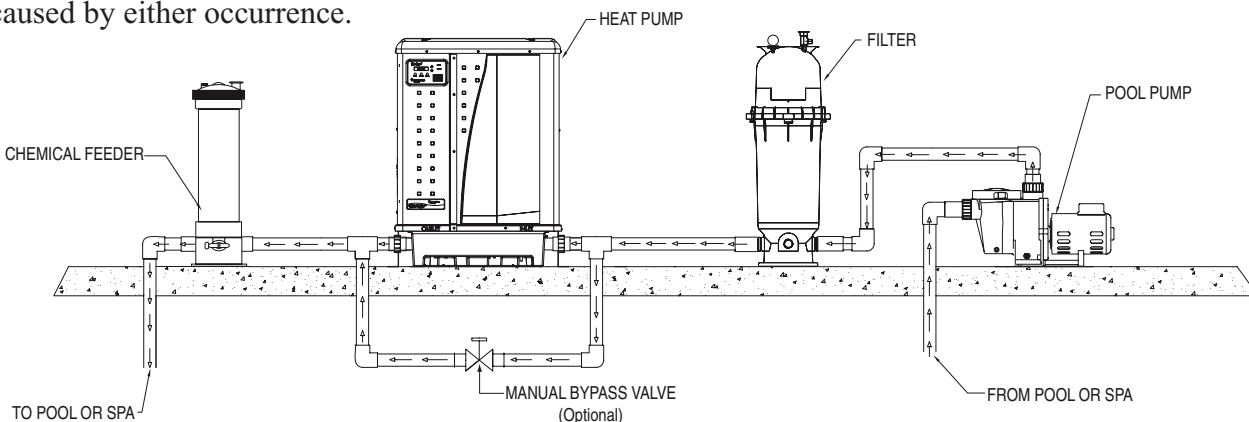

Figure 6. Standard Plumbing Layout

Water Connections at the Heat Pump

CAUTION — Make sure that flow requirements and pool water turnover rates can be maintained with the installation of additional heat pumps and plumbing restrictions.

Two inch Quick Connect fittings have been installed on the water inlet and outlet connections, see [Figure 7](#). Filtered cool water is plumbed to the inlet, located on the right side of the heat pump. Heated water flows through the outlet, located on the left side of the heat pump.

Plastic piping (PVC Schedule 40) should be connected to the heat pump. The unions, provided with the unit, accept 2 in. PVC pipe.

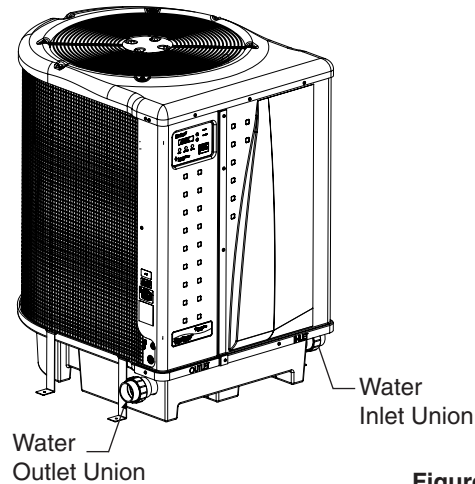

Figure 7.

Automatic Flow Control Valve

The inlet/outlet header of the heat pump comes equipped with an internal automatic flow control valve. The automatic flow control valve maintains the proper flow through the heat pump at rates up to 100 gpm (380 lpm). If the filter system flow rate is higher than 100 gpm (380 lpm), install a manual bypass valve, see [Figure 6](#) on [page 7](#).

NOTE: *Be advised that if your circulation pump is over 2 HP or if the total flow exceeds 100 gpm (380 lpm), you will have to add an external bypass valve. Excess water flow will damage the heat exchanger.*

Multiple Unit Installation

Heat Pump, Heater and/or Solar Combination

In certain regions of the country it may be more economical to run a heat pump during the warmer months and a gas heater during the cooler months. In some situations it may be desirable to run the heat pump in the “Chiller” mode, if so equipped, during the hottest portion of the year and a heater during the cooler months. The Pentair heat pump may be used in conjunction with a gas or electric heater or any combination of heat sources including solar. All heat sources must be plumbed in series to work correctly and efficiently.

A recommended plumbing layout for a heat pump / heater / solar combination heating system for a pool / spa combination is shown in **Figure 8**. Your system may not contain all of these components, but the basic plumbing will apply by eliminating the component in the illustration that is not a part of your system.

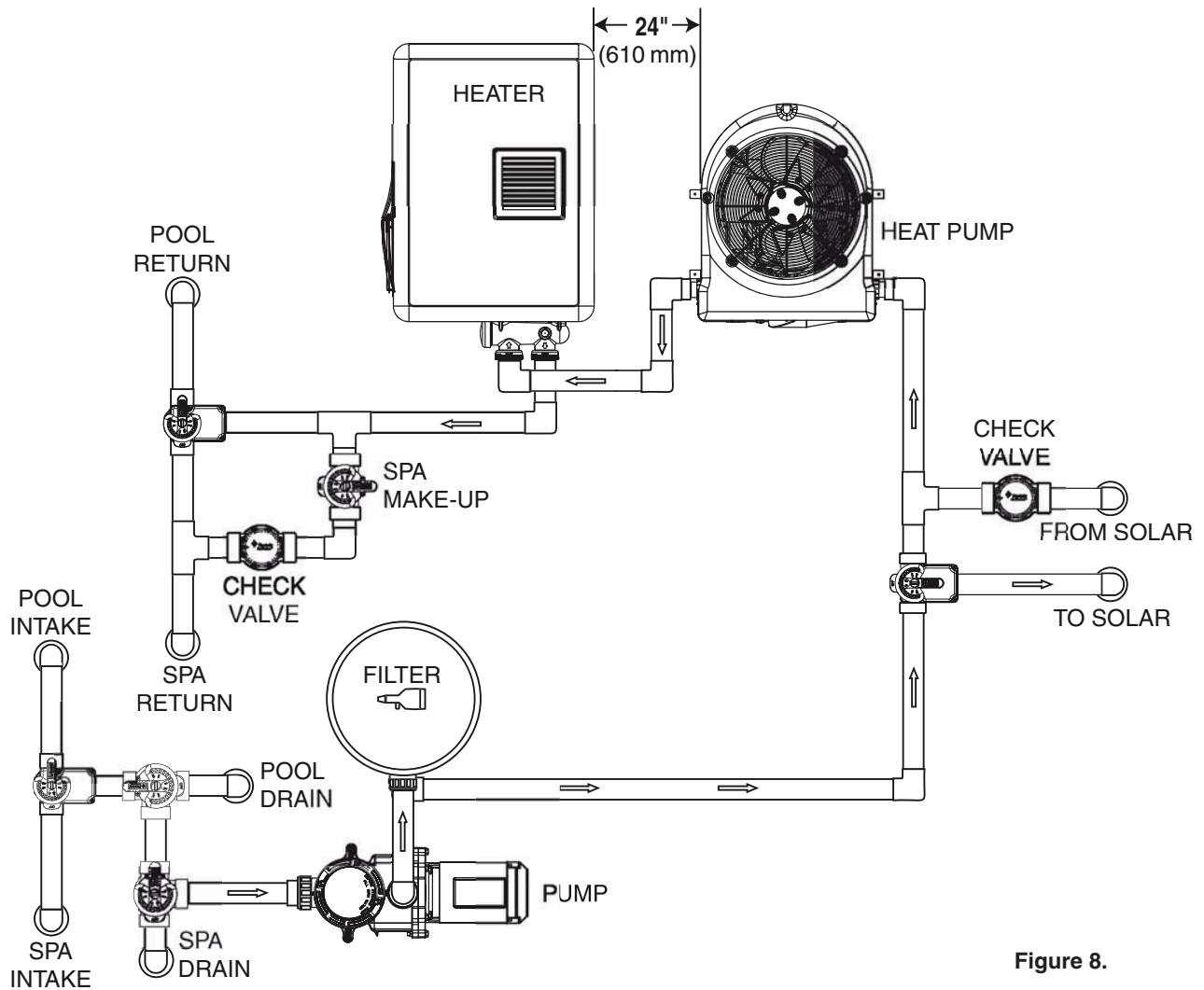

Figure 8.

Multiple Heat Pump Connections

All plumbing on multiple heat pump installations must be done in parallel see **Figures 9 and 10**. An equal flow of water to each heat pump is important for optimum operation.

NOTE: It may be necessary to adjust the water pressure switch if a unit is installed below the water level. See **page 16** for details on when and how to adjust the pressure switch.

Each heat pump allows a maximum flow rate of 100 gpm (380 lpm) and requires a minimum of 30 gpm (110 lpm).

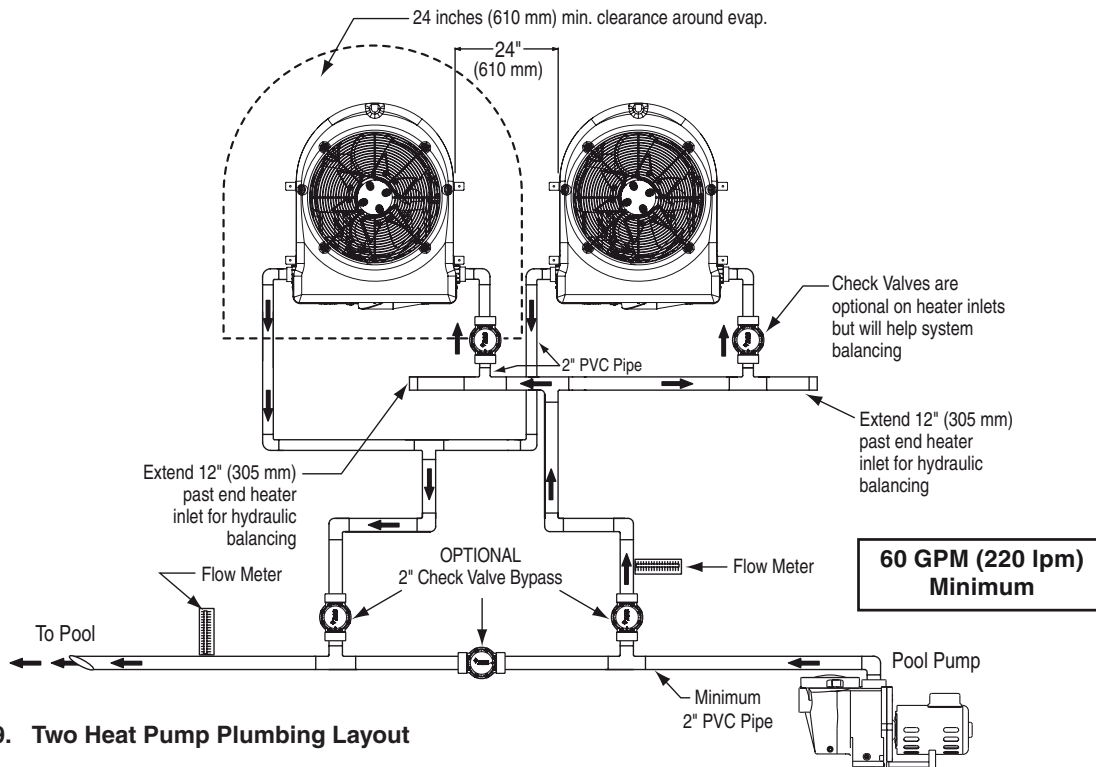

Figure 9. Two Heat Pump Plumbing Layout

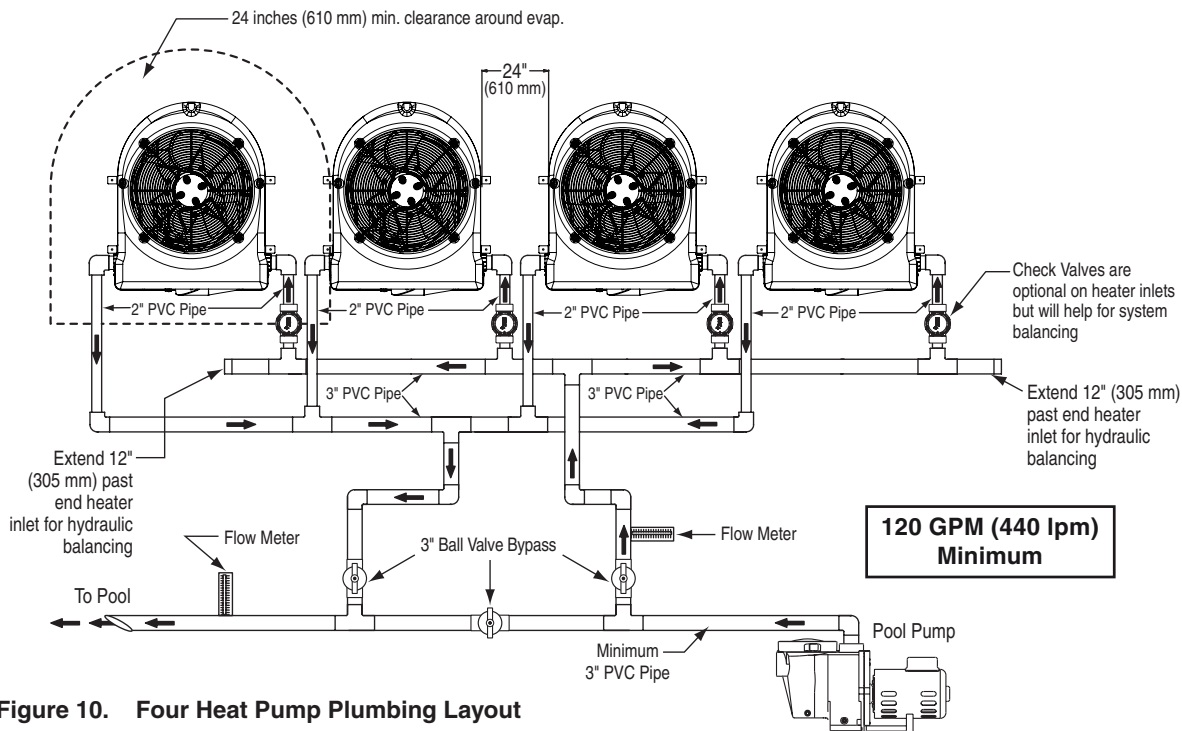



Figure 10. Four Heat Pump Plumbing Layout

Electrical Connections

 **WARNING** — Risk of electrical shock or electrocution.



This heat pump contains wiring that carries high voltage. Contact with these wires could result in death or serious injury to pool or spa users, installers, or others due to electrical shock, and may also cause damage to property. Always disconnect power circuit before connecting the heat pump.

 **CAUTION** — Label all wires prior to disconnection when servicing controls. Wiring errors can cause improper and dangerous operation. Verify proper operation after servicing.

General Information

Wiring connections must be made exactly as shown in the wiring diagram found on the inside of the heat pump access panel, see [Figures 18-20](#) on [pages 32-34](#). The heat pump must include a definite means of grounding and bonding. There is a ground lug inside the heat pump electrical compartment and a bonding lug on the left side of the heat pump.

Main Power

Electrical wiring to the heat pump must be in accordance with the latest edition of the National Electric Code (NEC), ANSI/National Fire Protection Association (NFPA) 70 in the United States, and in Canada, the Canadian Electrical Code (CEC) C22.1, unless local code requirements indicate otherwise. All wiring must be done by a certified electrician.

The following is the procedure to wire the heat pump to the electrical source:

Be sure the power to the circuit for the heat pump is turned off.

1. Remove the front left panel of the heat pump cabinet, (**you do not need to remove the torque head screw at the top left corner**).
2. Remove the service panel to the heat pump electrical compartment. (Front left corner of unit)
3. Electrical supply lines must be run through watertight conduit. Run the wires and conduit from the power source and connect them to the conduit connection on the left side of the heat pump.
4. Connect the power leads to the bottom terminals on the main compressor contactor as shown in the wiring diagram.
5. Verify that all other contactor wires are secure, they may have loosened during shipment.
6. Connect the ground wire to the ground lug provided on the bottom of the electrical compartment.
7. Replace the service panel and reinstall screws to hold it in place.
8. Replace the front left panel.
9. Connect a copper bonding wire (8 AWG) to the bonding lug on the left side of the heat pump.

Bonding

 **CAUTION** —This heater must be connected to a bonding grid with a solid copper wire not smaller in diameter than 8 ga.

The National Electrical Code and most other codes require that all metallic components of a pool structure, including reinforcing steel, metal fittings, and above ground equipment be bonded together with a solid copper conductor not smaller than 8 AWG. The heat pump, along with pumps and other pool equipment must be connected to this bonding grid. A bonding lug is provided on the left side of the heat pump to ensure this requirement is met.

Remote Operation

The heat pump may be connected to an automation system via the remote spade terminals on the back of the control board or via the RS-485 communication connector on the back of the control board.

NOTE: Remote connection via the RS-485 connector is only available on IntelliTouch® and EasyTouch® software version 1.11 or higher. All other automation packages must connect via the ¼ in. “Spade” terminals.

Relay Remote Controls

Electrical wiring must be in accordance with the latest edition of the NEC (NFPA 70) in the United States and CEC (CSA 22.1) in Canada, unless local code requirements indicate otherwise. To connect remote control equipment to the heat pump, perform the following steps:

1. Turn off the power to both the remote pool/spa control system and the heat pump.
2. Remove the front left panel of the heat pump cabinet, (**you do not need to remove the torque head screw at the top left corner**).
3. Remove the electrical service panel to the heat pump. Remove the 4 bezel retaining screws from above the electrical compartment and rotate the bezel downward. This will allow you to access the Remote terminals on the back of the heat pump control board for the remote control installation.
4. Run the wires from the pool/spa remote control system into the upper electrical compartment.
5. Connect the wiring from the pool/spa remote control system to the heat pump remote control terminals using ¼ in. “Spade” connectors as shown in the figure below.
6. Rotate the bezel back upwards into position and reinstall the 4 retaining screws.
7. Replace the electrical service panel.
8. Replace the front left panel.
9. Restore power to the heat pump and the pool/spa remote control system.
10. Press the Menu Select button to scroll to the Relay Remote screen. Toggle the selection by pressing one of the arrows until the screen displays “Relay Remote On”.

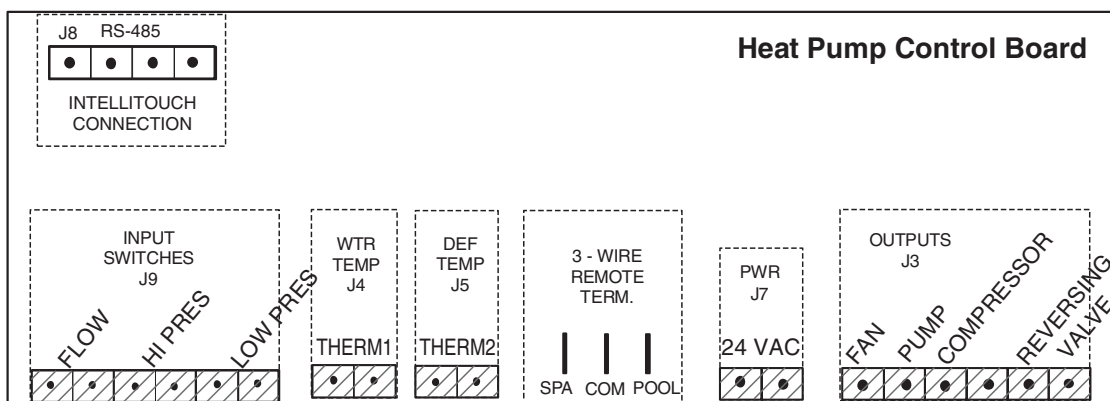

Figure 11.

¼ in. “Spade”
connectors

Connecting the Heat Pump to the IntelliTouch® or EasyTouch® Load Center via the Heat Pump Spade Terminals

To connect the heat pump cable to the Personality Board in the IntelliTouch® or EasyTouch® Load Center:

1. Turn off the main system power before making any connections.
2. Unlatch the front door spring latches, and open the front door of the IntelliTouch® or EasyTouch® Load Center.
3. Loosen the two retaining screws from the top of the control panel and lower the control panel down to access the Personality Board.
4. Run a UL approved conductor cable from the UltraTemp® to the Load Center.
5. Route the cable up through the low voltage raceway located on the left of the Load Center to the Personality Board, see [Figure 12](#).
6. Insert the UltraTemp® cable plug onto the gas heater terminal connector, located on the left side of the Personality Board.
7. If the heat pump is used in conjunction with a gas heater, use a 520403 Dual Heater Relay Kit. Plug the heat pump relay connector onto the SOLAR Terminal on the top center of the Personality Board. Follow the Dual Heater Relay Kit instructions for further set-up details. Be sure to install solar temperature sensor as per instructions.
8. Lift the control panel up into position and secure with the two screws.
9. Connect the cable from the IntelliTouch® or EasyTouch® Load Center to the heat pump remote control terminals using ¼ in. “Spade” connectors, see [Figure 11](#) on the previous page. Follow instructions for wiring on [page 12](#).

NOTE: Solar temperature sensor could be left loose in load center. The automation system does not use the temperature reading but just looks for resistance.

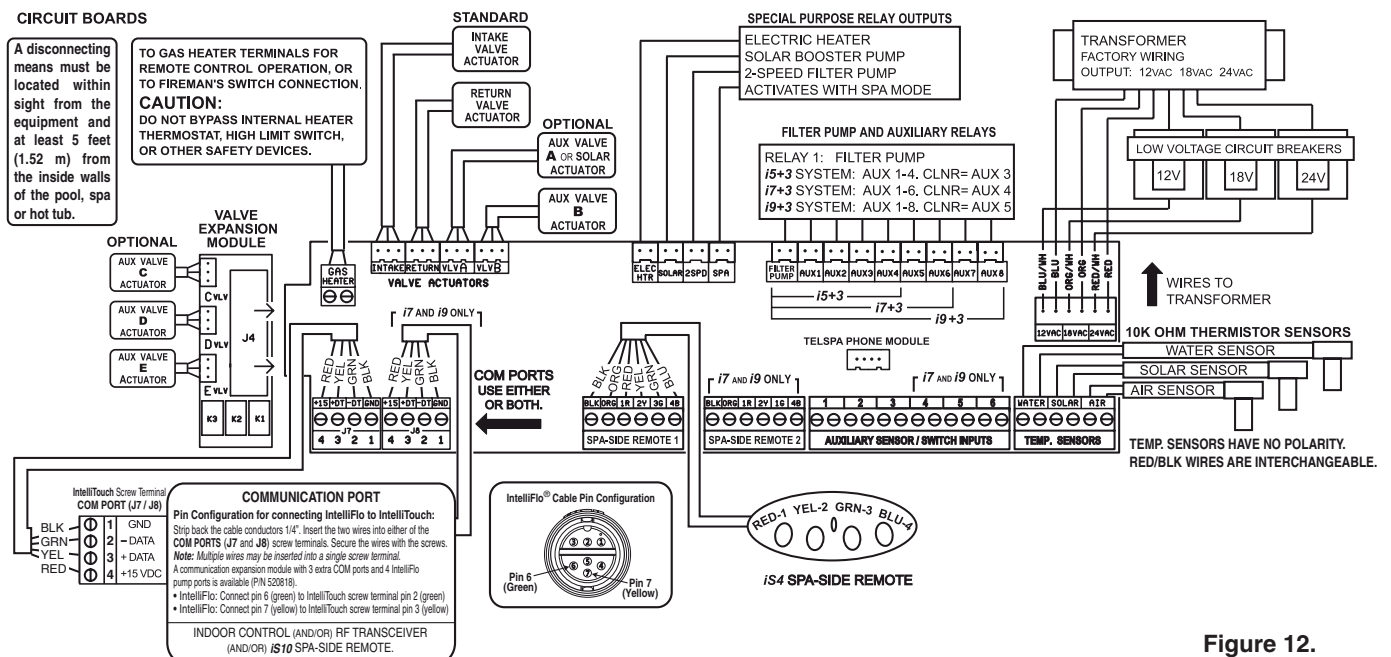

Figure 12.

Connecting the Heat Pump to the IntelliTouch® or EasyTouch® Load Center via the RS-485 Connector

The heat pump can be controlled by an IntelliTouch® or EasyTouch® system via the RS-485 communication cable. In this configuration, IntelliTouch® or EasyTouch® overrides present Temperature Set points on the heat pump and will start or stop the heat pump. The transfer of this data takes several seconds and causes a delay from when the command is given from the IntelliTouch® or EasyTouch® indoor control panel until the heat pump physically responds. This happens automatically but may take 1-2 minutes to complete.

NOTE: Heat pump control board set points will be shown but functionality disabled. For more information, refer to the IntelliTouch® User's Guide (P/N 520102) or the EasyTouch® User's Guide (P/N 520584) or the EasyTouch® Wireless System User's Guide (P/N 520688).

Connecting the Heat Pump Control Board to IntelliTouch® or EasyTouch® via RS-485

Connection from heat pump board to the IntelliTouch® or EasyTouch® system is via the optional four-wire cable (P/N 520199).

To connect the heat pump board cable to the IntelliTouch® or EasyTouch® load center:

CAUTION — Switch the main power off to the IntelliTouch® or EasyTouch® load center.

1. Unlatch the IntelliTouch® or EasyTouch® load center front door spring latches, and open the front door.
2. Remove the cover-panel screws securing the high voltage cover-panel, and remove it from the enclosure.
3. Loosen the two control panel access screws and fold down the outdoor control panel, see [Figure 13](#).
4. Insert the four-wire cable into plastic grommet on the bottom of the enclosure and route the wire up through the low voltage raceway to the Personality board.
5. Strip back the cable conductors ¼ in. Insert the wires into either of the **COM PORTS (J7 and J8)** screw terminals located on the left side of the Personality board. Secure the wires with the screws. For wiring details, refer to the pin configuration as shown on [page 15, Figure 14](#).

NOTE: Multiple wires may be inserted into single screw terminal.

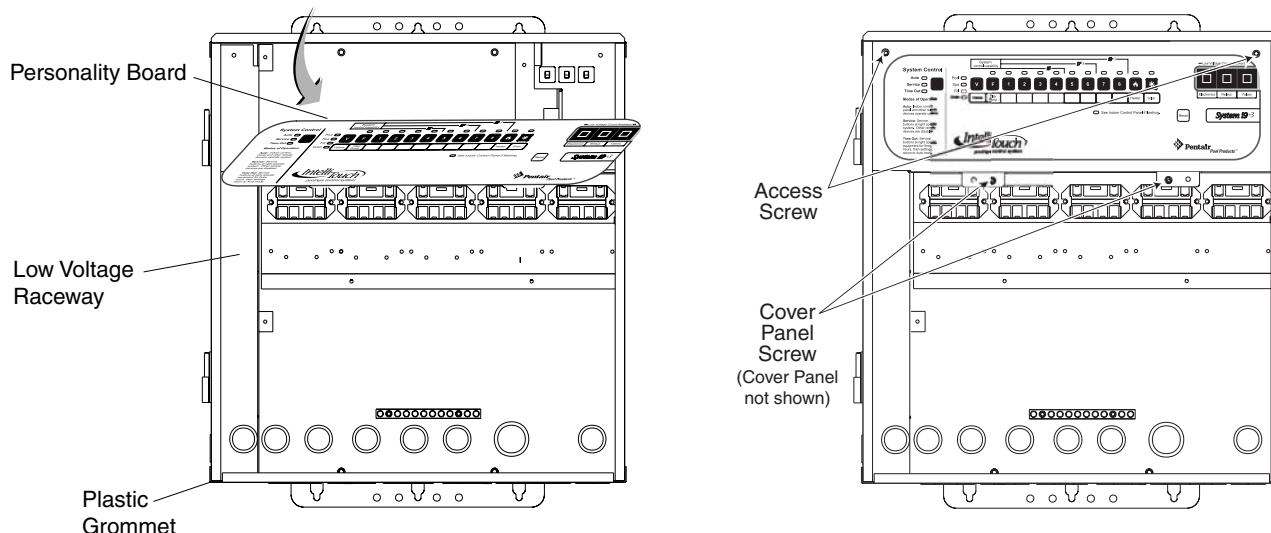

IntelliTouch® Load Center
Figure 13.

Connecting the Heat Pump Control Board to IntelliTouch® or EasyTouch® (Continued)

6. Close the IntelliTouch® control panel and secure it with the two access screws.
7. Install the high voltage panel cover and secure it with the two retaining screws.
8. Close the load center front door and secure with the two latches.
9. Switch power on to the IntelliTouch® load center.

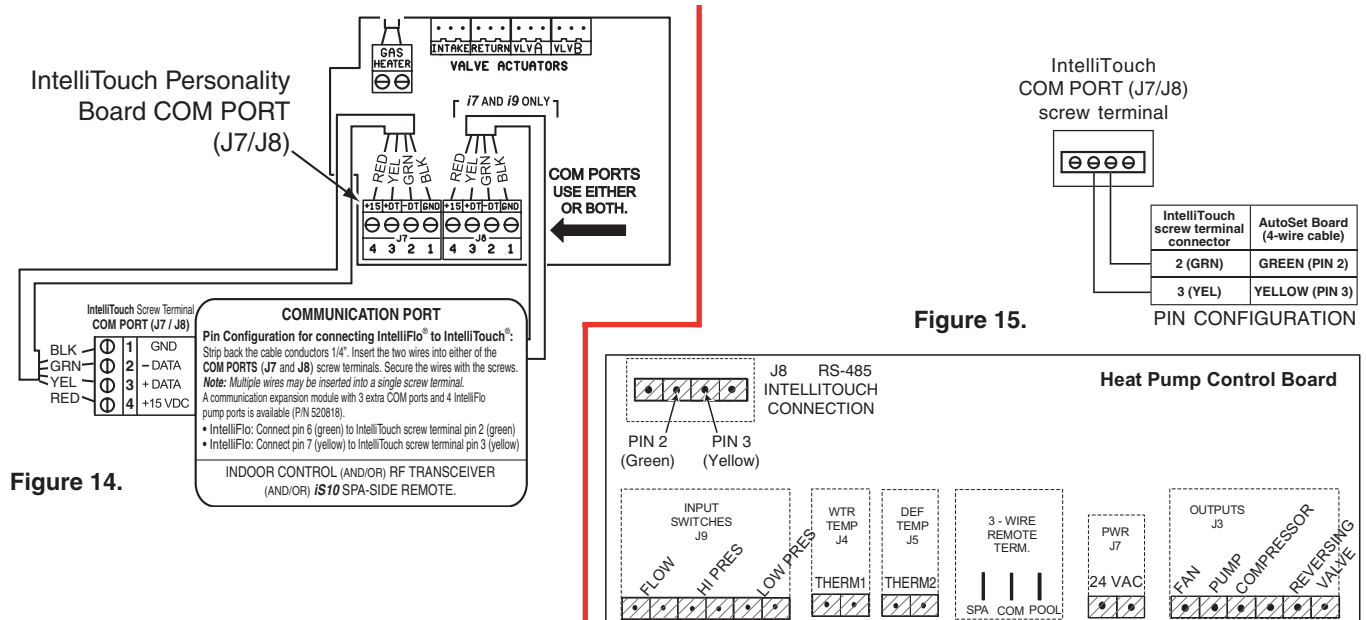

Pin Configuration for the Heat Pump Control Board to IntelliTouch®:

- Heat Pump Control Board: Connect pin 2 (green) to IntelliTouch® screw terminal pin 2 (green)
- Heat Pump Control Board: Connect pin 3 (yellow) to IntelliTouch® screw terminal pin 3 (yellow)

IMPORTANT — Do NOT use pin 1 (black) or pin 4 (red) on the AutoSet board or the IntelliTouch® mother board.

Connecting the IntelliTouch® or EasyTouch® to Heat Pump

1. Turn off the power to both the remote pool/spa control system and the heat pump.
2. Remove the front left panel of the heat pump cabinet, (**you do not need to remove the torque head screw at the top left corner**).
3. Remove the electrical service panel to the heat pump. Remove the 4 bezel retaining screws from above the electrical compartment and rotate the bezel downward. This will allow you to access the Remote terminals on the back of the Heat Pump control board for the remote control installation.
4. Run the wires from the pool/spa remote control system into the upper electrical compartment.
5. Connect the wiring from the IntelliTouch® Personality Board COM PORT to the RS-485 IntelliTouch® connection (J8) on the Heat Pump control Board. Connect the Green wire to J8 pin 2 and yellow wire to J8 pin 3. Do NOT use pin 1 (red) or pin 4 (black) wires. The connections are shown in the **Figure 15**.
6. Rotate the bezel back upwards into position and reinstall the 4 retaining screws
7. Replace the electrical service panel.
8. Replace the front left panel.
9. Restore power to the heat pump and the pool/spa remote control system.

Water Pressure Switch Adjustment



CAUTION — The water pressure switch should be adjusted to turn the heater off when the pump is off. Setting the switch to close at too low of a flow can damage the appliance. Adjust the switch to turn the heater off, not on.

The pressure switch is preset at the factory for activation at 1.5 psi [10 kPa]. This factory setting works for most basic installations as shown previously on pages 7, 9-10 in this manual. Only adjust the water pressure switch if the heat pump does not operate *when the proper flow is applied to unit* or if the heat pump does not shut off when the filter pump is off. Occasionally, unusual plumbing configurations or necessary restrictions in the plumbing may cause pressure sensing problems. In these rare situations, the plumbing system configuration may require adjustment of the water pressure switch. Adjustment of the pressure switch may be necessary if any part of the filter system piping is 3 feet [0.91 m] or more above the top of the heat pump.

In general, if the heat pump is installed more than 6 feet [1.83 m] below the pool surface, an external water flow switch must be added to the plumbing system.

On some installations, the piping from the heat pump to the pool is very short. The back pressure could be too low to trigger the pressure switch. If this happens, install a directional fitting or elbow where the return line enters the pool. This will increase back pressure for the heat pump to operate properly. Be sure to check that the system flow is above the minimum requirement of 30 gpm (110 lpm) after the directional fitting installation.

Be sure the pool filter is clean before making any pressure switch adjustment: A dirty filter will restrict the water flow and the pressure switch cannot be adjusted properly.

To adjust the pressure switch:

The following adjustment is for installations where the heat pump is *below* pool water level.

1. Be sure that all valves in the system are set to allow water flow through the heat pump. Start the filter pump.
2. Set the heat pump temperature above the actual temperature to call for heat. Turn the heat Pump **ON**.
3. Once the heat pump is running, turn off the filter pump. The heat pump should turn off immediately.
4. If the heat pump continues to operate when the filter pump is off, then the water pressure switch needs to be adjusted.
5. Remove the heat pump's left front panel and remove remaining right front panel. The water pressure switch is located in the water plumbing in the lower right corner of the heat pump.
6. Slowly rotate the adjustment wheel on the water pressure switch in a **clockwise** direction until the "**LOW WATER FLOW**" Alarm shows on the LCD, the Red Service LED turns **ON**, and the heat pump stops.
7. Check the setting of the water pressure switch by starting and stopping the filter pump and checking the control panel and operation of the heater between each flow change.
8. If the water pressure switch cannot be adjusted to accommodate the conditions listed above, an external flow switch must be added to the plumbing system to ensure that the heat pump will not operate without the proper flow through the heat exchanger.

The following adjustment is for installations where the heat pump is *above* pool water level.

1. Be sure that all valves in the system are set to allow water flow through the heat pump. Start the filter pump.
2. Set the heat pump temperature above the actual temperature to call for heat. Turn the heat Pump **ON**.
3. If the LCD shows a "**LOW WATER FLOW**" Alarm and Red Service LED is present then the water pressure switch needs to be adjusted.
4. Remove the heat pump's left front panel and remove remaining right front panel. The water pressure switch is located in the water plumbing in the lower right corner of the heat pump.
5. Slowly rotate the adjustment wheel on the water pressure switch in a **counterclockwise** direction until the "**LOW WATER FLOW**" Alarm and Red Service LED vanish, time delay countdown will start.
6. Once the heat pump is running, turn off the filter pump. The heat pump should turn off immediately.
7. If the heat pump continues to operate when the filter pump is off, turn the adjustment wheel on the water pressure switch in a **clockwise** direction until the "**LOW WATER FLOW**" Alarm shows on the LCD, the Red Service LED turns **ON**, and the heat pump stops.
8. Check the setting of the water pressure switch by starting and stopping the filter pump and checking the control panel and operation of the heater between each flow change.
9. If the water pressure switch cannot be adjusted to accommodate the conditions listed above, an external flow switch must be added to the plumbing system to ensure that the heat pump will not operate without the proper flow through the heat exchanger.

Section 3

Operating the Heat Pump

This section describes how to operate the heat pump.

Initial Start-up Precautions

CAUTION — Do not use this heat pump if any part has been under water. Immediately call a qualified service technician to inspect the heater and replace any part of the control system which has been under water.

CAUTION — Keep all objects off the top of the heat pump. Blocking air flow could damage the unit and may void the warranty.

ATTENTION

After starting the heat pump, please note that there is a **5 minute delay** before the compressor begins operation. The heat pump display will show the remaining delay time in minutes and seconds.

Be sure that there is water in the pool and that the surface level is above the skimmer or other inlets of the pool's filter system.

The pool pump must be on and water flowing through the heat pump for it to operate.

With any new pool or spa installation, operate the filter pump with the heat pump off long enough to completely clean the water. This will remove any installation residue from the water. Clean the filter at the end of this operation before starting the heat pump. When raising the temperature of a cold pool, program the time clock to run the pump continuously. This lets the filter system and heat pump operate continuously until the water reaches the temperature setting on the temperature control. When that happens, the heat pump will automatically shut off, but the filter pump will keep running.

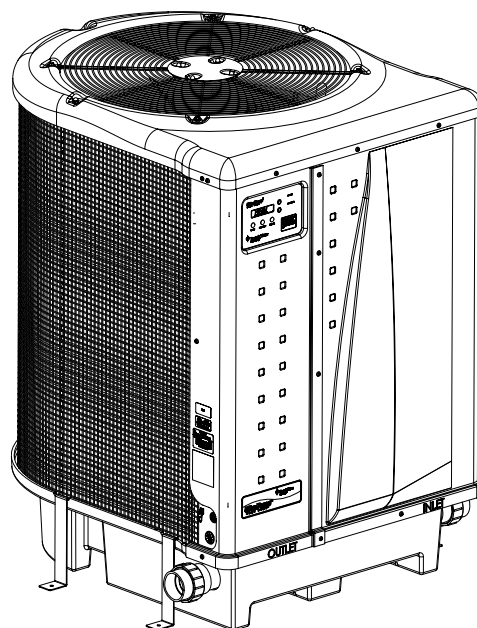

Figure 16.

Heat Pump Control Panel Overview

Control Panel Layout

1. **ON/OFF** button – Turns the heat pump On and Off.
2. **MENU SELECT** button – If pressed from the Run Screen it will bring up the Menu Select Menu Tree Screens. It is also used to scroll through the Operator Setup Menu Tree.
3. **POOL/SPA** button – On the first press the current heat, cool or auto mode will be displayed along with the active set point, pool or spa. On subsequent presses, the use of the pool or spa set points will be toggled. The operator can also toggle between the pool and spa set point by using the UP and DOWN arrows.
4. **UP and DOWN Arrow** buttons – The UP and DOWN arrows will raise or lower the temperature set point if pressed while the run screen is displayed. They are also used to scroll through the various parameter values on the Menu Select and Operator Setup screens.
5. **Liquid Crystal Display (LCD)** – Displays water temperature, set point temperature and heat pump parameters.
6. **ON Light** – Illuminated green when the heat pump is on.
7. **SERVICE Light** – Illuminated red when an alarm condition exists.

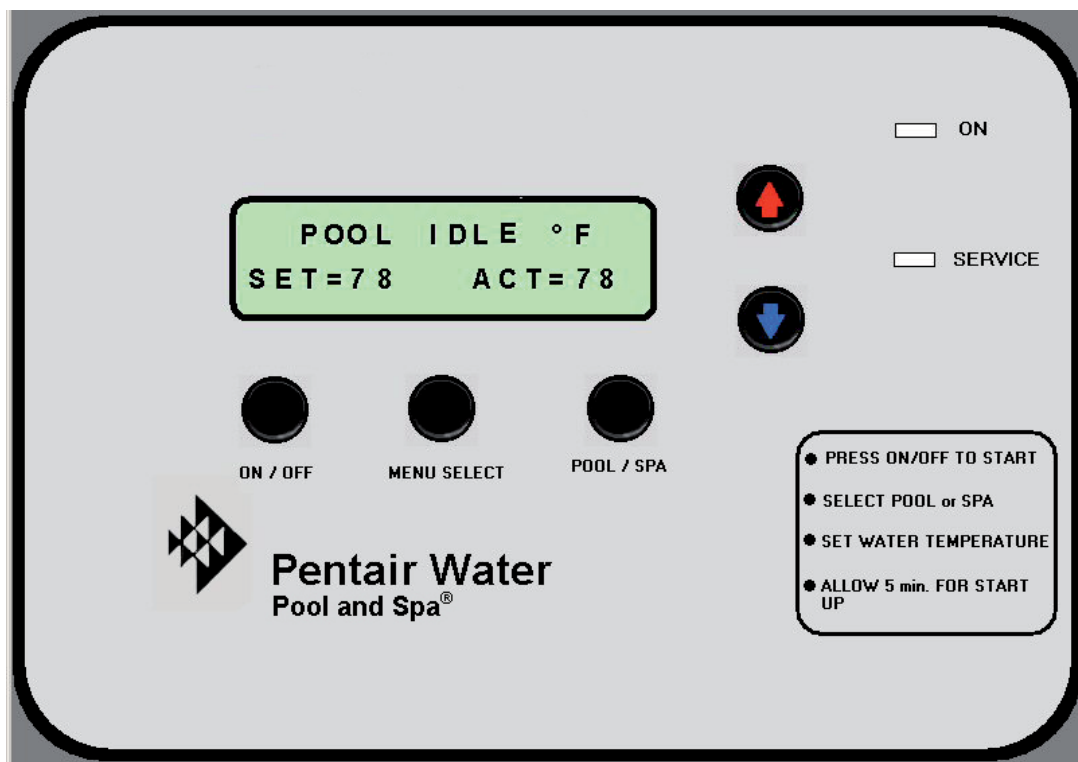

Figure 17. Heat Pump Main Control Panel

Control Panel Operation

1. **Starting and Stopping the Heat Pump** – The heat pump is started and stopped with the ON/OFF button.
 - a. Starting - If power is supplied to the heat pump and the ON light is not illuminated, pressing the ON/OFF button will start the heat pump which causes the ON light to illuminate.
 - b. Stopping - If the ON light is illuminated, pressing the ON/OFF button will stop the heat pump causing the ON light to be extinguished. The screen shown below will be displayed temporarily.

PENTAIR WATER
HEAT PUMP OFF

2. **Changing the Set Point** – The control board has 2 independently adjustable temperature set points. One set point is for the pool temperature control and the other for temperature control of the spa. The active mode of operation (pool or spa) is defined as the “active” set point.
 - a. The value of the pool or spa temperature set point is adjusted by pressing the UP or DOWN arrow buttons when the associated pool or spa run screen is displayed. The temperature set point is displayed after the letters SET in the lower left corner of the display. The number after ACT= on the bottom row is the actual measured water temperature.

POOL
IDLE/HEAT/COOL
SET=_ ACT=_

SPA
IDLE/HEAT/COOL
SET=_ ACT=_

- b. The set point need not be active to be adjusted. Press the MENU SELECT button repeatedly until the associated run screen is displayed. With that screen displayed, adjust the set point with the UP and DOWN arrows. The screen will automatically return to the active run screen after 15 seconds of keypad inactivity.
 - c. The active set point can be changed in one of the following two ways:
 - i. On the first press of the POOL/SPA button the current heat, cool or auto mode will be displayed along with whether the pool or spa set point is active. On subsequent presses, the use of the pool or spa set points will be toggled. The operator can also toggle between the pool and spa set point by using the UP and DOWN arrows when this screen is displayed.
 - ii. The Auto Mode screen can also be made active by repeatedly pressing the MENU SELECT button. Once the Auto Mode screen is displayed the active set point can be toggled between pool and spa by pressing the UP or DOWN arrows.

AUTO MODE
POOL/SPA

3. **Heat, Cool and Auto Modes Operation** – Certain models have the ability to both heat and cool.
- a. These heat pumps can be setup to operate in any one of three modes:
 - i. Heat only mode
 - ii. Cool only mode
 - iii. Automatic Heat and Cool - The heat pump automatically switches between heat and cool based on whether the water temperature is below or above the active set point.
 - b. If the cooling option is available, the operating modes can be changed as described here. Press the MENU SELECT button repeatedly until the Heat or Cool screen is displayed. Once displayed, press the UP or DOWN arrows to scroll through the heat, cool and auto options. The last option shown on the display will become active.

HEAT/COOL/AUTO
 SET TO - H/C/A

4. **Heat Pump Timer** – This feature is an adjustable timer to allow the heat pump to run (Green LED ON) and then turn OFF (Green LED OFF) for a predetermined amount of time. During the selected time frame the Green LED Indicator is ON and the heat pump will function in the normal mode of operation and/or the operator can change set points, functions, etc. The heat pump's Green LED Indicator will turn OFF and the heat pump will stay OFF when time expires. Countdown time is in hours and minutes.

HEAT PUMP RUNTIME
 REMAINING - NONE

- a. To activate the heat pump timer, press the MENU SELECT button repeatedly until the heat pump timer screen is displayed. With that screen displayed, press the UP arrow to increase the amount of time. The DOWN arrow will decrease the amount of time.
 - i. An adjustable time from 10 minutes to 99 hours in 10 minute increments by use of the UP or DOWN arrows.
 - ii. Time is shown in Hours and Minutes.
 - iii. Enabled by the first press of the UP arrow (going from NONE to the first 10 minutes) or DOWN arrow (going from NONE to 99 hours).
 - iv. The first press will also turn the heat pump on if it is not already on. Green LED illuminates and fan turns on.
 - v. When the timer is active (in countdown), the operator can increase or decrease the time remaining within the current screen using the arrow buttons.
 - vi. This feature will not be active in Relay Remote or Serial Remote modes. The above screen will still be displayed, but operator will not be able to adjust the time. Turning Relay ON will automatically disable the Heat Pump timer.
 - vii. Any RS-485 valid communication received will reset the timer to zero. The RS-485 overrides the heat pump timer operation.
 - viii. The timer can be disabled by pressing DOWN and POOL/SPA Buttons simultaneously or just pressing the ON/OFF button.

5. **Relay Remote** – In relay remote operation, the heat pump is started and stopped by remote relays which are connected to the remote POOL, COMMON and SPA quick connect connectors on the back of the control board. When conductivity is provided between the pool and common connections or the spa and common connections, the heat pump will start as long as the water temperature is not over the local set point (under for chiller operation). The local set points are active in relay remote operation.
- a. To activate the relay Remote Mode, press the MENU SELECT button repeatedly until the Relay Remote screen is displayed. Once displayed, press the UP or DOWN arrows to toggle between ON and OFF. The last option shown on the display will become active.

RELAY REMOTE
 REMOTE ON/OFF

6. **Serial Remote** – In serial remote operation, the heat pump is made to start and stop via a serial RS-485 communications link with a Pentair automation controller. When operating in this mode, the heat pump's local set point is disregarded. The heat pump will heat or cool as told by the automation controller without regard to the local set point. However, the high and low temperature faults are still active so the heat pump will not heat above 104° F. or cool below 45° F. To use the Serial Remote mode, the Intell Address screen from the Operator Setup Menu Tree must be assigned to the proper address. One (1) is the most commonly used address.
- a. The Address on the IntelliTouch® Address screen must match the address being used on the IntelliTouch®. The IntelliTouch® address can be changed from the Operator Setup Menu as described below:
 - i. Press the UP and DOWN arrows simultaneously. The Language Selection screen should be displayed.

LANGUAGE/IDIOMA
 SELECTED - ENGLISH

- ii. Then press the MENU SELECT button repeatedly until the Intell Address screen is displayed. Once displayed, press the UP or DOWN arrows to select the address being used in the automation controller. The last address shown on the display will become active.

INTELL ADDRESS
 ADDRESS = 1-16

7. **Temperature Scales** – The control board can display temperatures in either degrees Fahrenheit or Celsius. The temperature scale in use can be changed from the Operator Setup Menu Tree as described below:
- a. Press the UP and DOWN arrows simultaneously. The Language Selection screen should be displayed.

LANGUAGE/IDIOMA
 SELECTED - ENGLISH

- b. Then press the MENU SELECT button repeatedly until the Temperature Scale screen is displayed. Once displayed, press the UP or DOWN arrows to toggle between the Fahrenheit and Celsius options. The last option shown on the display will become active.

TEMPERATURE SCALE
 FAHRENHEIT / CELSIUS

8. **Temperature Offset** – The control board provides the ability to increase or decrease the measured water temperature by 2 degrees. This is setup in the Operator Setup Menu Tree as described below:

- a. Press the UP and DOWN arrows simultaneously. The Language Selection screen should be displayed.

LANGUAGE/IDIOMA
 SELECTED - ENGLISH

- b. Then press the MENU SELECT button repeatedly until the Temperature Offset screen is displayed. Once displayed, press the UP or DOWN arrows to select the desired offset. The last number shown on the display will become active.

TEMP OFFSET
 OFFSET = -2 TO +2

9. **AutoSet Operation** – The AutoSet feature periodically energizes a contactor which can be connected to the pump to move water through the heat pump. This allows the heat pump to sense the temperature of the body of water whose temperature is being maintained. After a temperature stabilization delay, the heat pump will determine if it needs to start or not. If the temperature is at the desired level, the heat pump does not start and the filter pump contactor is de-energized. If the water temperature is not at the desired level, the heat pump starts and will run, along with the filter pump, until the water reaches the desired temperature. At that point the filter pump and the heat pump will stop. (See AutoSet on [page 8](#) for further details/example.)

- a. The AutoSet feature is enabled in the Main Menu Tree as follows. Press the MENU SELECT button repeatedly until the AutoSet screen is displayed. Once displayed, press the UP or DOWN arrows to toggle between the on and off options. The last option shown on the display will become active.

AUTOSET
 OVERRIDE IS ON/OFF

Timers And Delays

1. **Water Sensing Timer** – One minute timer to allow water from the pool to reach the Heat Pump before acquiring temperature. This timer initiates when water first begins to run from stopped or low water flow conditions or when the heat pump is turned ON. Countdown time is in Minutes and Seconds.

SENSING WATER TEMP
REMAINING = 1:00

2. **Restart Delay Timer** – Five minute timer is a protection feature for the heat pump's compressor. This extends the life of the compressor's by not allowing it to cycle on and off, (*i.e.* adjusting set point up and down around actual temperature). Countdown time is in minutes and seconds.

RESTART DELAY
REMAINING = 1:00

3. **Defrost Delay Timer** – Fifteen minute timer where the Heat pump is in Defrost operation. Countdown time is in minutes and seconds. See Defrost section on [page 29](#) for more details.

DEFROST DELAY
REMAINING = 15:00

4. **Pump Start Delay** – One to Four Hour timer used in conjunction with the AutoSet feature. Counts down the time until the control board will energize the internal contactor in the heat pump to turn on. Countdown time is in hours and minutes. See AutoSet section for more details.

PUMP START DELAY
REMAINING = 4:00

5. **Heat Pump Runtime Timer** – This feature is an adjustable timer to allow the heat pump to run (Green LED ON) and then turn OFF (Green LED OFF) for a predetermined amount of time. During the selected time frame the Green LED Indicator is ON and the heat pump will function in the normal mode of operation and/or the operator can change set points, functions, etc. The heat pump's Green LED Indicator will turn OFF and the heat pump will stay OFF when time expires.

HEAT PUMP RUNTIME
REMAINING - NONE

Control Panel Menu Tree Screens

(Press MENU SELECT Button)

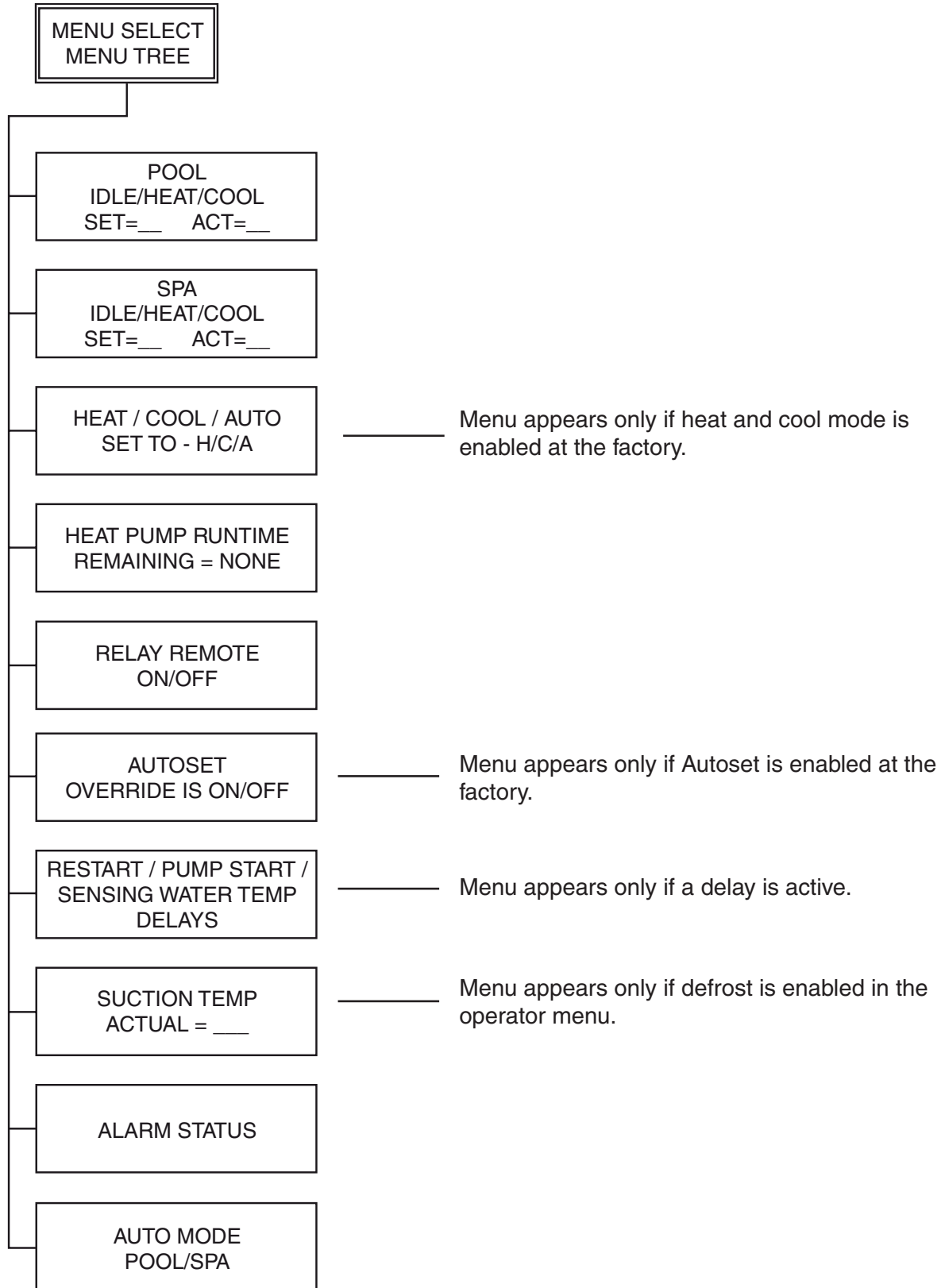

Control Panel Menu Screens

To scroll through the menu screens press the MENU SELECT button to view each screen. While in the menu screens, if no activity is detected after 15 seconds, the main screen is displayed.

1. **Pool Run Screen** – Displays whether the heat pump is idle, heating or cooling if the Pool set point is active. This screen also displays the water temperature set point and the actual measured water temperature. The Pool set point can be raised or lowered using the UP and DOWN arrows while this screen is displayed. The display will automatically return to this screen after 15 seconds of push button inactivity when the Pool set point is active.

POOL
 IDLE/HEAT/COOL
 SET=_ ACT=_

2. **Spa Run Screen** – Displays whether the heat pump is idle, heating or cooling if the Spa set point is active. This screen also displays the water temperature set point and the actual measured water temperature. The Spa set point can be raised or lowered using the UP and DOWN arrows while this screen is displayed. The display will automatically return to this screen after 15 seconds of push button inactivity when the Spa set point is active.

SPA
 IDLE/HEAT/COOL
 SET=_ ACT=_

3. **Heat or Cool Mode Selection Screen** – *This screen is only shown on Auto Heat and Cool Heat pumps, not on heat only units.* On these units this screen allows the operator to switch the heat pump between heat-only, cool-only and auto heat/cool modes.

HEAT/COOL/AUTO
 SET TO - H/C/A

4. **Heat Pump Timer Screen** – This feature is an adjustable timer to allow the heat pump to run (Green LED ON) and then turn OFF (Green LED OFF) for a predetermined amount of time.

HEAT PUMP RUNTIME
 REMAINING - NONE

5. **Relay Remote On/Off Screen** – Allows the operator to turn the Relay Remote mode On and Off. In Relay Remote mode, the heat pump is started and stopped by remote relays in an automation controller. The local Pool and Spa set points are still active in this Relay Remote mode.

RELAY REMOTE
 REMOTE ON/OFF

6. **AutoSet On/Off Screen** – *This screen is only shown if the AutoSet mode is enabled during factory setup.* Allows the operator to turn the AutoSet mode On and Off. AutoSet mode periodically energizes a filter pump contactor to start a remote filter pump which allows the heat pump to heat or cool the water as necessary.

AUTOSET
OVERRIDE IS ON/OFF

7. **Time Delay Screen** – If the heat pump is waiting on any of the restart, pump start or sensing water temperature delays this screen shows how much delay time is left.

RESTART / PUMP START/
SENSING WATER TEMP
DELAYS

8. **Alarm Screen** – If an alarm condition is present it will be displayed on this screen. If no alarms are present the screen will display ALARM STATUS NONE. The control board has the ability to store a 30 Alarm history of previous alarms that have occurred. At the alarm status screen, press the DOWN arrow. The first alarm will be the most recent alarm that has occurred. Successive presses (up to 30) of the DOWN arrow will display the alarm history in the order of occurrence. The operator can scroll back up using the UP button. There is an option to erase the history.

ALARM STATUS
NONE

First and second press sequence of the DOWN arrow.

FIRST PRESS

LATEST ALARM
LOW WATER FLOW

SECOND PRESS

ALARM PRIOR #1
HIGH REFRIG

9. **Auto Mode Screen** – Displays whether the heat pump is in Heat only, Cool only or Auto mode. It also displays whether the Pool or Spa set point is active. The active set point can be switched between Pool and Spa by using the UP and DOWN arrows.

AUTO MODE
POOL/SPA

Operator Setup Menu Tree Screens

(Press UP and DOWN Arrows Simultaneously)

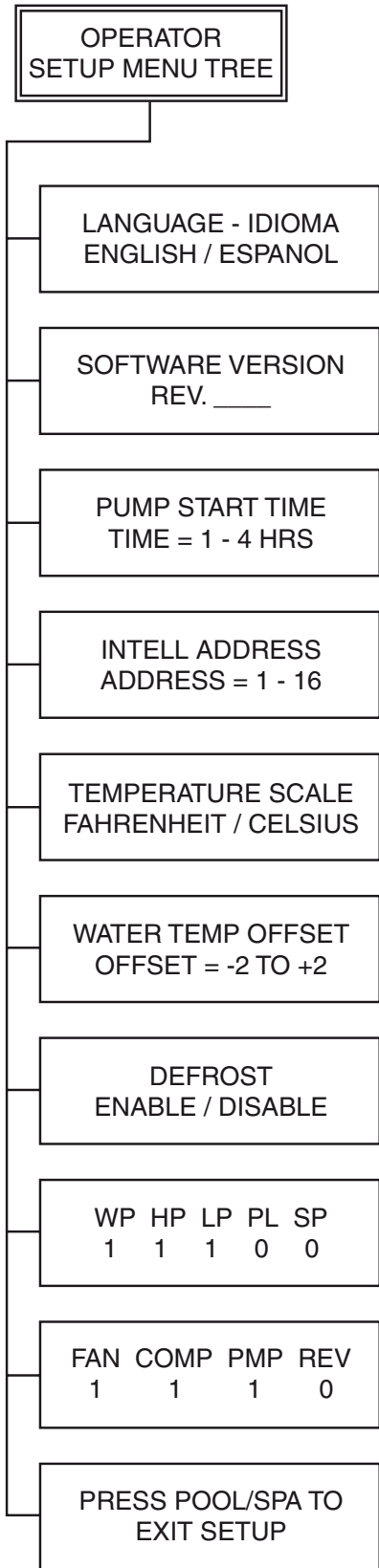

**

**THE NUMBER ONE (1) IS DISPLAYED WHEN THE ASSOCIATED INPUT/OUTPUT IS ON AND ZERO (0) IS DISPLAYED WHEN THE ASSOCIATED INPUT/OUTPUT IS OFF.

INPUT STATUS

WP = WATER PUMP SWITCH
 HP = HIGH REFRIGERANT PRESSURE SWITCH
 LP - LOW REFRIGERANT PRESSURE SWITCH
 PL - POOL REMOTE
 SP - SPA REMOTE

OUTPUT STATUS

FAN - FAN
 COMP - COMPRESSOR
 PMP - FILTER PUMP
 REV - REVERSING VALVE

Operator Setup Menu Screens

To access this menu, press the **Up** and **Down** arrows simultaneously. While in the Operator Setup Menu screen, if no activity is detected after 15 seconds, the main screen is displayed. To get back into the Setup menu you must press the **Up** and **Down** arrows simultaneously again.

1. **Language Selection** – Displays the language selected. Select either English or Spanish using the UP and DOWN arrows.

LANGUAGE/IDIOMA
 SELECTED - ENGLISH

2. **Software Revision** – Displays the software revision level loaded on the control board.

SOFTWARE VERSION
 REV._

3. **Pump Start Time** – This displays the period at which the heat pump will close the AutoSet contactor to start the filter pump. Adjustable from 1 to 4 hours using the UP and DOWN arrows.

PUMP START TIME
 TIME = 1 - 4 HRS

4. **Intell Address** – IntelliTouch® RS-485 Communications Address which must match the address used in the IntelliTouch® or EasyTouch® automation controller being communicated with. Adjustable from 1 to 16 using the UP and DOWN arrows.

INTELL ADDRESS
 ADDRESS = 1-16

5. **Temperature Scale** – Determines if the water temperature actual reading and set point is displayed in degrees Fahrenheit or Celsius. Adjusted between Fahrenheit and Celsius using the UP and DOWN arrows.

TEMPERATURE SCALE
 FAHRENHEIT / CELSIUS

6. **Temp Offset** – Adjusts the measured water temperature up or down to allow the operator to match the heat pump measured temperature to a remote temperature monitoring device. The offset can be varied from -2 to +2 using the UP and DOWN arrows.

TEMP OFFSET
 OFFSET = -2 TO +2

7. **Defrost Screen** – Allows to Enable/Disable defrost cycle.

DEFROST
 ENABLE / DISABLE

Operator Setup Menu Screens

8. **Input Screen** – The Input screen is a diagnostic display which shows the status of the input sensors. The number 1 is displayed when the associated input is on and zero is displayed when the associated input is off.

WP	HP	LP	PL	SP
1	1	1	0	0

WP = Water Pump Switch

HP = High Refrigerant Pressure Switch

LP = Low Refrigerant Pressure Switch

PL = Pool Remote

SP = Spa Remote

9. **Output Screen** – The Output screen is a diagnostic display which shows the status of the Output devices. The number 1 is displayed when the associated output is on and zero is displayed when the associated output is off.

FAN	COMP	PMP	REV
1	1	1	0

FAN = Fan

COMP = Compressor

PMP = Pump

REV = Reversing valve

10. **Exit** – Pressing the POOL/SPA button while this screen is displayed returns the display to the Pool or Spa Run Screen as appropriate.

PRESS POOL/SPA TO EXIT SETUP

Locking The Control Panel

1. **Heat pump control panel lock-out** – To prevent unwanted adjusting or manipulating of the heat pump settings, the control panel can be locked. Once locked, if any button is pressed, the display will read:

HEAT PUMP CONTROLS LOCKED

- To activate the control panel lockout, press the MENU SELECT and POOL/SPA buttons simultaneously.
- To unlock the control panel, press the MENU SELECT and POOL/SPA buttons simultaneously.

Defrost Cycle

At air temperatures around 50° F, the heat pump may enter a defrost cycle. The defrost cycle is initiated when a sensor on the evaporator detects that the refrigerant temperature has fallen below the defrost set point. At this time, the heat pump compressor will stop. The heat pump evaporator fan will continue to run, and will draw air over the evaporator fins for about 15 minutes. If, at the end of the 15 minutes, the temperature sensor detects a temperature above 44° F, the compressor will restart. Otherwise the unit will shut down.

Because a heat pump's efficiency decreases as air temperature decreases, it is preferable to operate the heat pump during the warmest time of day. As a rule, the unit should not be operated during the coolest time of day, or when the air temperature falls below 45° F.

Autoset

Autoset is a feature that allows the heat pump to automatically turn on your water circulation pump at predetermined time intervals after the water circulation pump shuts off. To utilize this feature, the water circulation pump must be wired in parallel with your mechanical time clock using the auxiliary relay supplied in the high voltage power panel of the heat pump.

For example, if your pool water circulation pump is wired properly with the time clock through the heat pump, have the heat pump control board programmed with a pump start time interval of 4 hours, have the AutoSet feature enabled, and you wish to maintain your pool to 80° F., this is the sequence of events that will happen.

1. If your mechanical time clock is set to shut off at 9:00 p.m., once the water circulation pump shuts off, the heat pump will display a countdown window.

PUMP START DELAY
REMAINING = 4:00

2. The heat pump will continue to countdown in hours and minutes.
3. Once the 4 hours has expired, at 1:00 am, the control board will energize the internal contactor in the heat pump to turn on your water circulation pump.
4. The heat pump will sense water temperature then determine if it needs to continue to circulate water. If the pool temperature has fallen below your set point, 80 degrees for this example, the heat pump will turn on and begin heating the pool. Once the pool temperature has reached its set point, 80 degrees, the heat pump will shut off and will also shut off the water circulation pump.
5. If after the water sensing time, the heat pump detects the pool water is above the set point, 80 degrees for this example, it will shut off and shut the water circulation pump off also.
6. At the time the water circulation pump shuts off, the heat pump will again reset and begin the countdown interval again and display the following window.

PUMP START DELAY
REMAINING = 4:00

7. The heat pump will continue this cycle every time the water circulation pump is shut off.
8. Once the time clock turns on in the morning, the heat pump will stop the AutoSet feature and resume normal operation.

Control Panel Alarm Messages

HIGH WATER TEMP	Water temperature is above 108°.
LOW WATER TEMP	Water temperature is below 40°.
LOW WATER FLOW	The pressure switch sensing water flow is open.
REMOTE POOL SPA	Pool and Spa relay remote inputs are simultaneously energized.
WATER THERM SHORT	Water temperature thermistor circuit shorted.
WATER THERM OPEN	Water temperature thermistor circuit open.
SUCTION TH SHORT	Defrost thermistor circuit shorted.
SUCTION TH OPEN	Defrost thermistor circuit open.
BROWNOUT	The 24 VAC supply voltage to the control board is low.
HIGH REFRIG	Refrigerant high pressure switch is open.
LOW REFRIG	Refrigerant low pressure switch is open.
FIVE ALARMS	Indicates that 5 faults have occurred in one hour. This fault will automatically reset in one hour or can be manually reset by pressing the ON/OFF button.

Wiring Diagram – (Single Phase – 50Hz/60Hz)

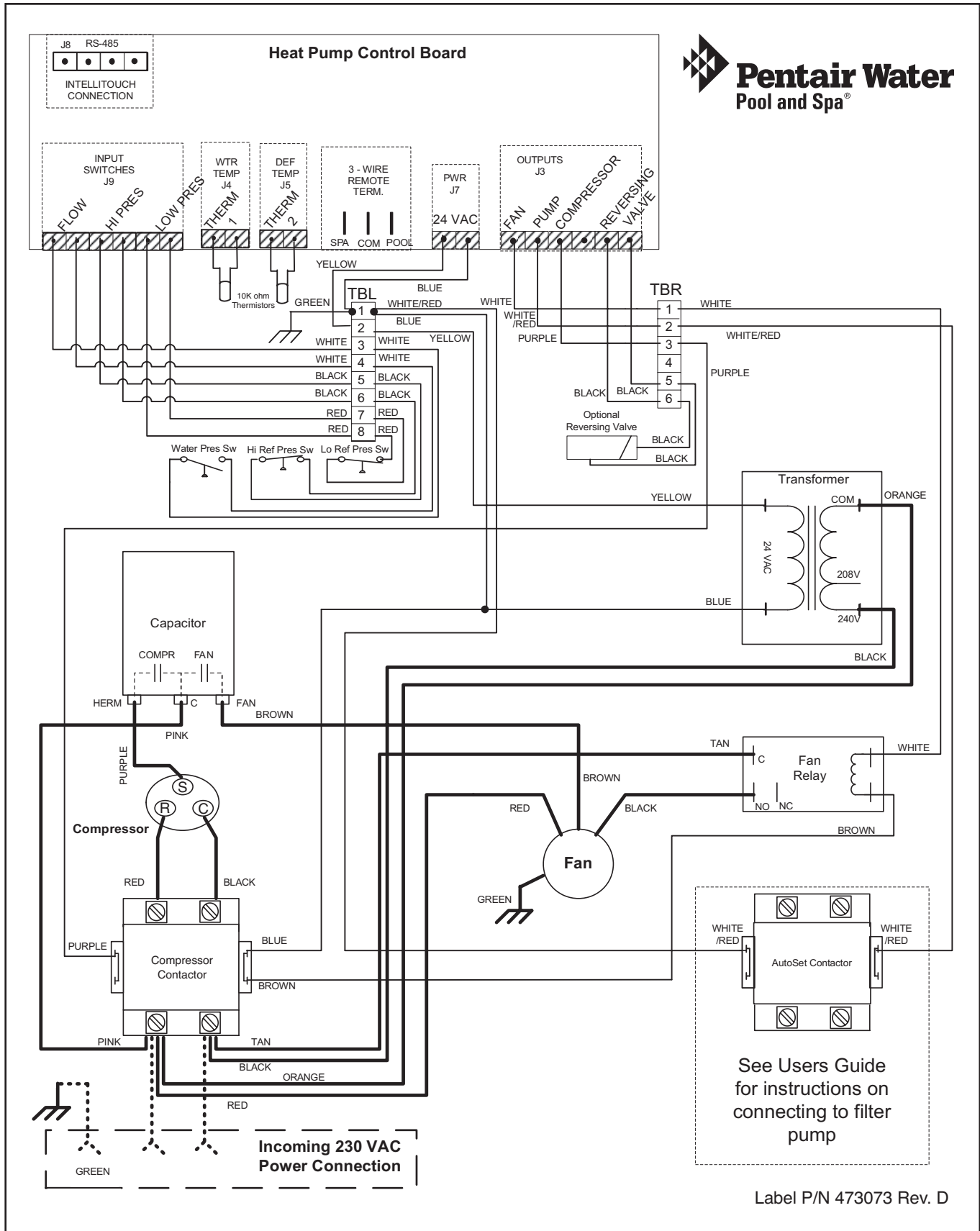

Figure 18.

Wiring Diagram – (Three Phase – 60Hz)

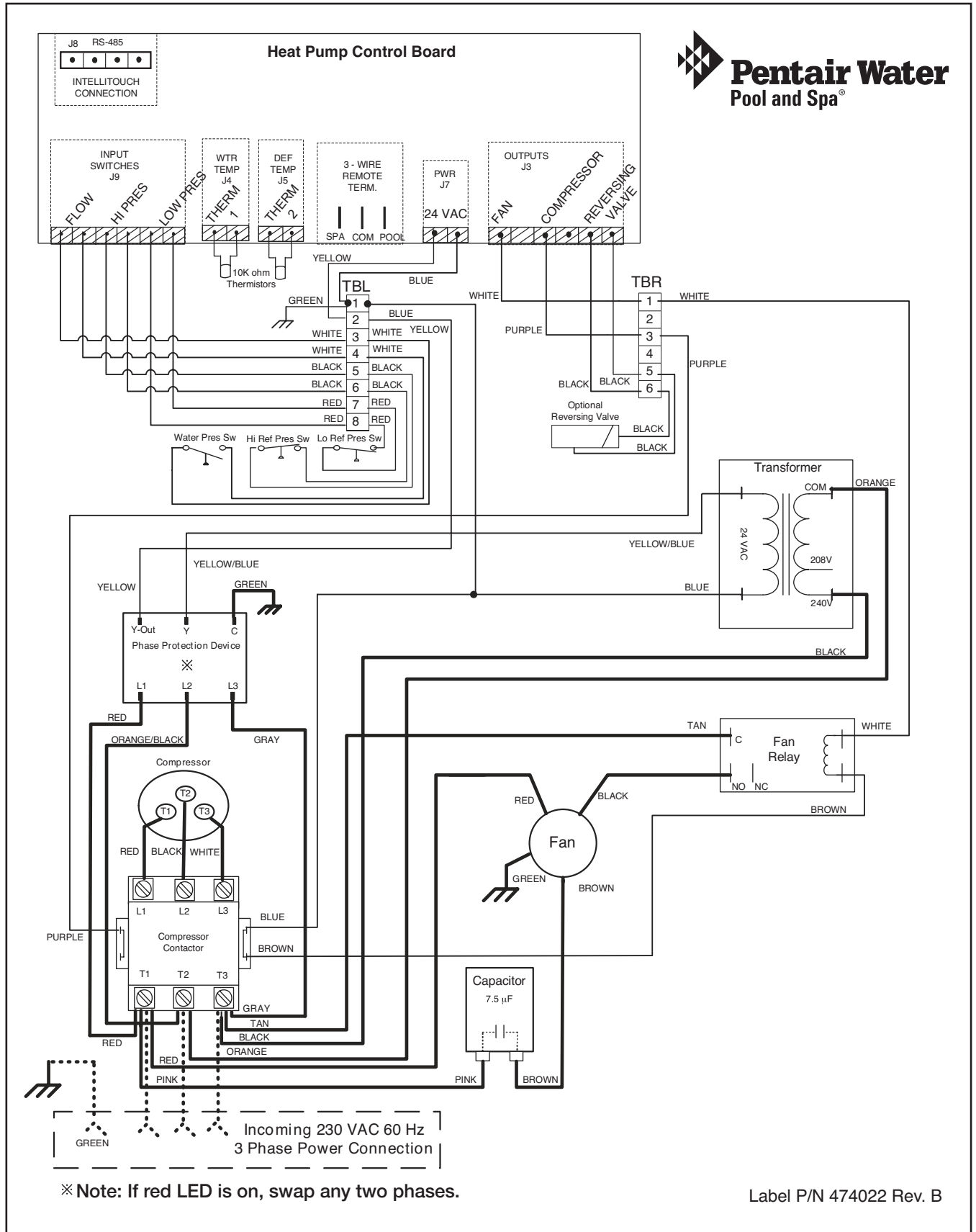

Figure 19.

Wiring Diagram – (Three Phase – 50Hz)

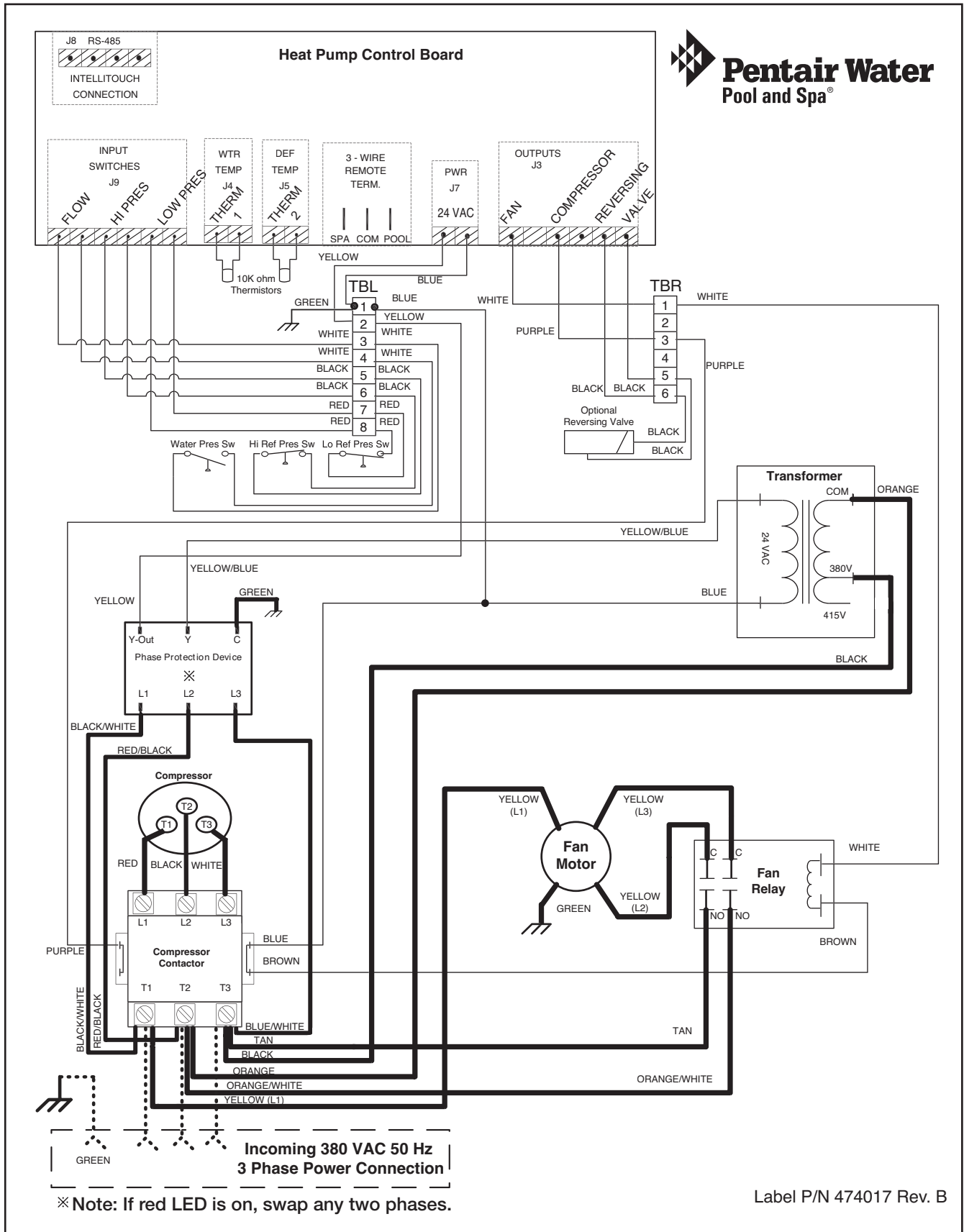
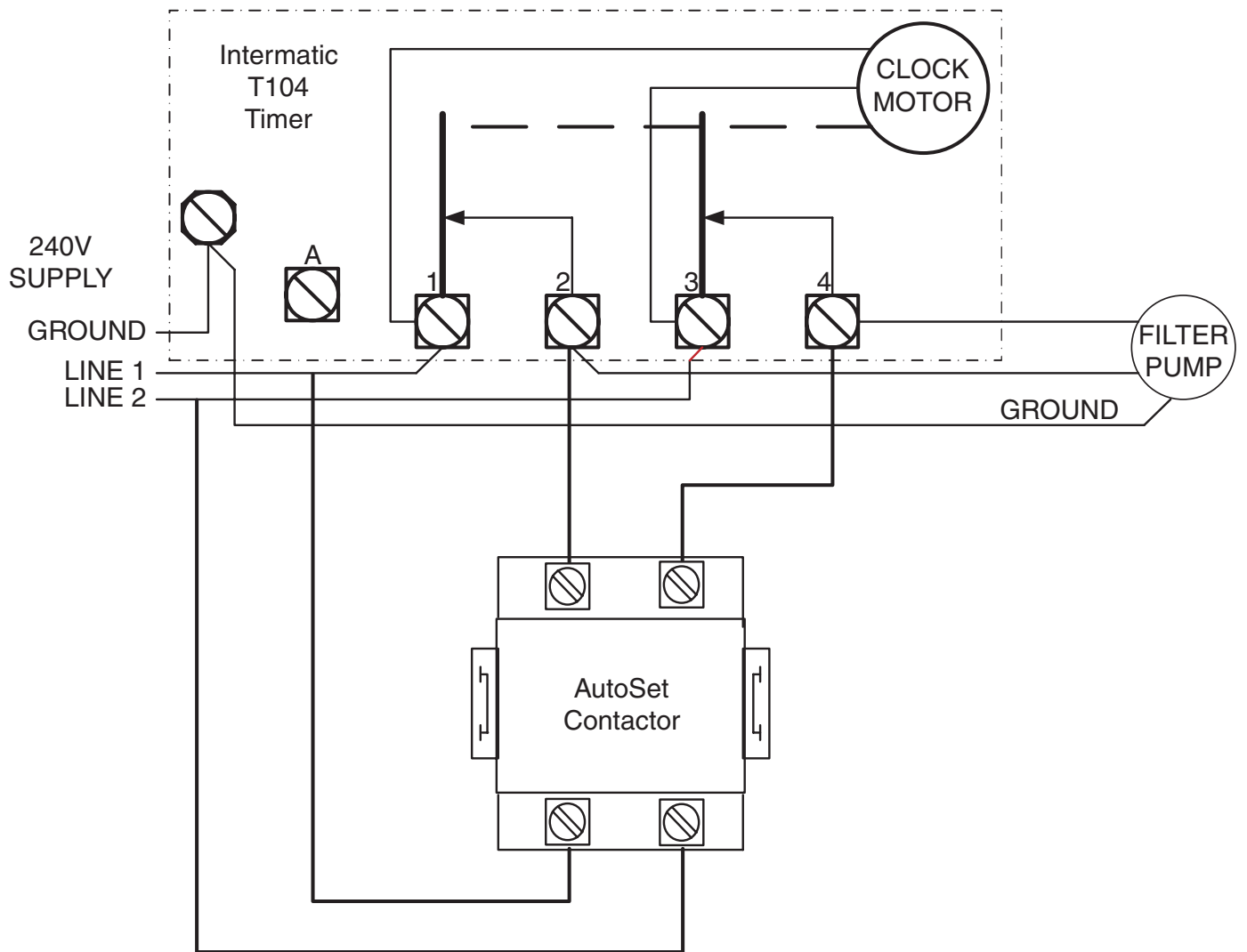

Figure 20.

AutoSet Contactor to Mechanical Timer Wiring Example



NOTES:

1. Mechanical timer is not provided with the heat pump.
2. Example only, other timers will be similarly wired.
3. Ensure that the electrical power lines are not crossed when making connections.

Figure 21.

Section 4

General Maintenance

Water Chemistry

Proper chemical balances are necessary for sanitary bathing conditions as well as ensuring your heat pump's long life. Be sure to keep your chemical and mineral concentration levels within the values indicated in Table 1. *Failure to maintain proper water chemistry may cause damage to the heat pump and may void the warranty.*

Table 1. Optimal Water Chemistry Ranges

Test	Recommended Level
Free Chlorine <i>or</i>	1.0 to 3.0 ppm (3.0 to 5.0 spa)
Bromine	2.0 to 4.0 ppm (3.0 to 5.0 spa)
pH	7.4 to 7.6
Total Alkalinity (TA)	80 to 120 ppm
Calcium Hardness (CH)	200 to 400 ppm
Cyanuric Acid	30 to 50 ppm
Total Dissolved Solids (TDS)	Less than 2000 ppm
Copper	0 ppm
* Concentration levels taken from "Basic Pool and Spa Technology" published by NSPI (National Spa and Pool Institute).	

NOTE: For spas, it is also necessary to perform water changes in addition to chemical treatment. It is recommended to change the spa water every 60 days for light usage and every 30 days if usage is heavy.

Winterizing

CAUTION — Failure to winterize could cause damage to the heat pump and will void the warranty.

In areas where freezing temperatures occur, you should protect your pump, filter, and heat pump from the elements. Perform the following steps to completely drain the heat pump, see [Figure 22](#).

1. Turn off the electrical power to the heat pump at the main breaker panel.
2. Shut off the water supply to the heat pump.
3. Disconnect the water inlet and outlet unions located on the lower front panel of the heat pump.
4. Blow out the water lines.
5. Cover only the top of the heat pump to prevent debris from falling into the unit. Do not wrap the sides of the heat pump with any plastic or other material that will retain heat or moisture inside the unit.

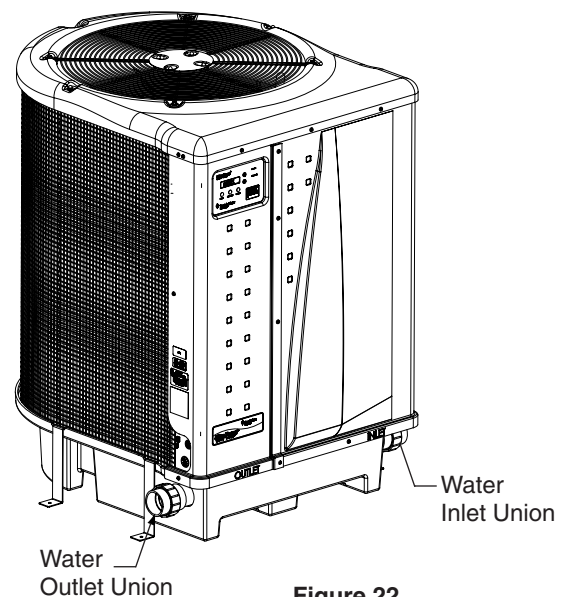

Figure 22.

Spring Start-Up

If your heat pump has been winterized, perform the following steps when starting the system in the Spring:

1. Uncover the heat pump and inspect the top and sides for any debris or structural problems.
2. Connect the water inlet and outlet unions located on the lower front panel of the heat pump.
3. Turn on the filter pump to supply water to the heat pump. Open the filter air bleeder and circulate water through the system long enough to bleed all the air out of the pool system. Check for leaks in and around the heat pump.
4. Turn on the electrical power to the heat pump at the main breaker panel.

Inspection and Service

Pentair Heat Pumps are designed and constructed to provide long performance life when installed and operated properly under normal conditions. Periodic inspections are important to keep your heat pump running safely and efficiently through the years. Failure to properly maintain your unit may void your warranty.

Owner Inspection

Pentair recommends that you inspect your heat pump on a continual basis and especially after abnormal weather conditions. The following basic guidelines are suggested for your inspection:

1. Make sure the front of the unit is accessible for future service.
2. Keep the top and surrounding areas of the heat pump clear of all debris.
3. Keep all plants and shrubs trimmed and away from the heat pump.
4. Keep lawn sprinkler heads from spraying on the heat pump to prevent corrosion and damage. Use a deflector if needed.
5. If the unit is installed under a very sharp roof pitch or under a roof without a gutter, a gutter or diverter should be fitted to prevent excessive water from pouring down into the unit.
6. Do not use this heat pump if any part has been under water. Immediately call a qualified professional technician to inspect the heat pump and replace any part of the control system which has been submerged.

The heat pump will produce condensation (water) while in operation. The heat pump base is designed to allow the condensation to exit through the bottom drain port when the unit is running. The condensation will increase as the outdoor air humidity level increases. Check the following at regular intervals to ensure proper condensate drainage:

1. Visually inspect and clear the bottom drain ports of any debris that could clog the ports.
2. Keep the top air flow discharge and air flow intake area clear of debris so the air flow through the heat pump is not restricted. The cooler discharge air from the top should not accumulate and be drawn into the side air intake coils.
3. Ensure that condensate run-off is properly directed away from the equipment pad to keep it from undermining the pad.
4. Ensure that condensate water does not puddle inside the heat pump.

During normal operation, the heat pump produces three to five gallons of condensate per hour. If condensate drainage is above this range during operation or if water continues to drain from the base when the heat pump is not in operation for more than an hour, a leak in the internal plumbing may have occurred. Call a qualified heat pump technician to investigate the problem.

Professional Maintenance and Service

The Pentair line of Heat Pumps are some of the most efficient ways to heat a pool or spa. The heat pump transfers heat from the outside air to the pool or spa water by means of an internal heat exchanger.

When the fan is turned on, warm air is drawn through the R410A refrigerant charged air coil, turning the cold liquid refrigerant to a warm gas. The gas then flows through the compressor, which increases the pressure and refrigerant temperature. The hot refrigerant gas enters the water-to-gas heat exchanger where the water is heated and returned to the pool. During this heat exchange process the refrigerant is cooled and returned to the air coil and the cycle repeats.

NOTE: The maximum heat output and efficiency of a heat pump is dependent upon the quality and performance of the major components used. Equally important are the environmental conditions (for example, air temperature, humidity, water temperature, and wind). To maintain maximum performance and efficiency, keep the air coil clean from dirt and debris. It is recommended to clean your air coil once a year by flushing the coil with compressed air or hosing off the coil with a garden hose. Care should be taken to not bend the coil fins as this will restrict the airflow and lower your heat pump performance.

DO NOT USE A PRESSURE CLEANER ON THE UNIT.

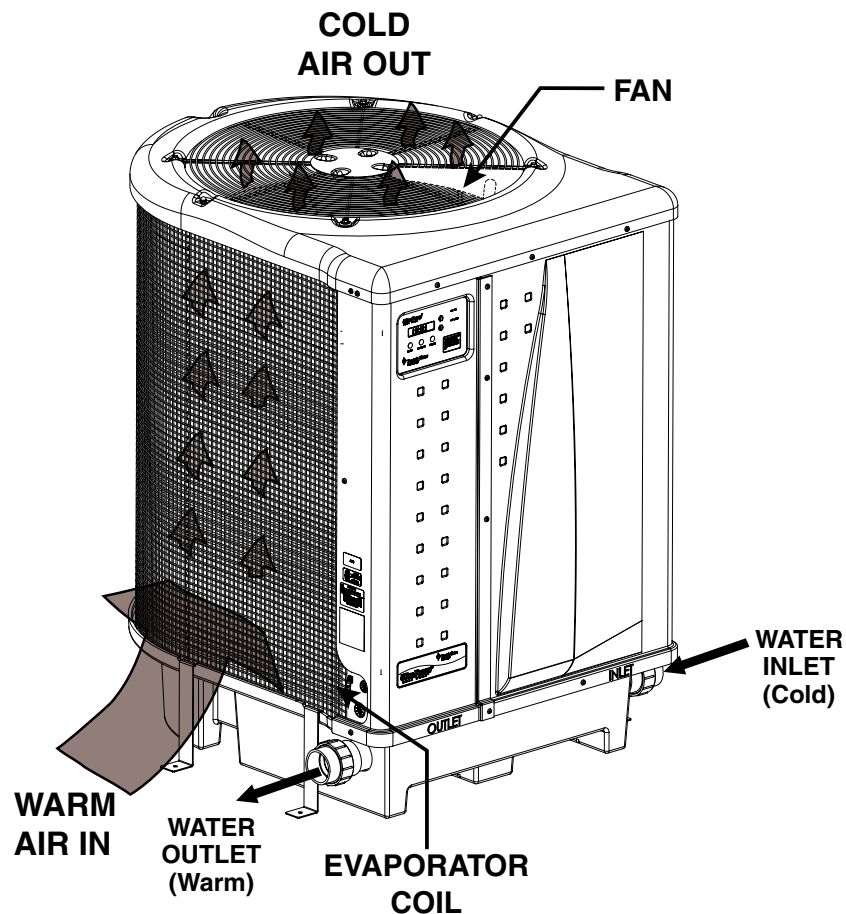

Figure 23. Typical Heating Cycle

Section 5

Troubleshooting

Use the following troubleshooting information to resolve possible problems with your heat pump.

 **WARNING — RISK OF ELECTRICAL SHOCK OR ELECTROCUTION.**



Improperly installation will create an electrical hazard which could result in death or serious injury to pool users, installers, or others due to electrical shock, and may also cause damage to property. **Do NOT** attempt any internal adjustments inside the heater.

1. Keep your hands and hair clear of the fan blades to avoid injury.
2. If you are not familiar with your pool filtering system and heater:
 - a. **Do NOT** attempt to adjust or service without consulting your dealer, professional pool or air conditioning contractor.
 - b. Read the entire Installation & User's Guide before attempting to use, service or adjust the heater or pool filtering system. The water pressure switch should be adjusted to turn the heater off when the pump is off. Setting the switch to close at too low of a flow can damage the appliance. Adjust the switch to turn the heater off, not on.

Note: Turn off power to unit prior to attempting service or repair.

Problem or Symptoms	Possible Cause	Corrective Action
HIGH WATER TEMP Alarm: Water temperature above 108° F.	Bad Thermistor or bad control board.	Test water temp to see if it is correct, if not, use the 10k ohm resistance test to verify thermistor. If bad, replace thermistor. If good, replace control board. ★
LOW WATER TEMP Alarm: Water temperature below 40° F.	Bad Thermistor or bad control board.	Test water temp to see if it is correct, if not, use the 10k ohm resistance test to verify thermistor. If bad, replace thermistor. If good, replace control board. ★
LOW WATER FLOW Alarm: The pressure switch sensing water flow is open.	1. Water circulation pump not on.	Verify water circulation pump is on.
	2. Insufficient water flow.	Dirty or worn filters or clogged lint traps. Verify filter is clean, backwash if necessary to clean entire filter system or replace filter element if needed. Inspect & clean pump impeller. Adjust Plumbing valves. Repair suction air leaks.
	3. External bypass open.	Make sure external water bypass around heat pump is closed.
	4. Bad water pressure switch.	With water flowing, check resistance of water pressure switch, if open, replace switch.
REMOTE POOL SPA Alarm: Pool and Spa remote inputs are simultaneously energized.	Remote pool, spa, and common spade terminals on the back of the control board are all energized.	Modify automation control output so that only either the pool and common or spa and common terminals are energized.
WATER THERM SHORT Alarm: Water temperature sensor circuit is shorted.	Bad Thermistor or bad control board.	Use the 10k ohm resistance test to verify thermistor. If shows shorted, replace thermistor. If good, replace control board. ★
WATER THERM OPEN Alarm: Water temperature sensor circuit is open.	Bad Thermistor, or bad control board.	Use the 10k ohm resistance test to verify thermistor. If shows open, replace thermistor. If good, replace control board. ★
SUCTION TH SHORT Alarm: Defrost refrigerant temperature sensor circuit is shorted.	Bad Thermistor or bad control board.	Use the 10k ohm resistance test to verify thermistor. If shows shorted, replace thermistor. If good, replace control board. ★
SUCTION TH OPEN Alarm: Defrost refrigerant temperature sensor circuit is open.	Bad Thermistor or bad control board.	Use the 10k ohm resistance test to verify thermistor. If shows an open, replace thermistor. If good, replace control board. ★

★ Refer to 10K Ohm Temperature Resistance Chart on page 42.

NOTE: Any service must be done by an authorized service agency person.

Problems or Symptoms	Possible Cause	Corrective Action
BROWNOUT Alarm: The 24 VAC supply voltage to the control board is low. CAUTION: High Voltage Checks. Observe extreme caution or call dealer or factory for advice before attempting to Troubleshoot Electrical Box.	1. Bad transformer	Supply voltage to the transformer should be between 208 and 260 volts. Transformer should output between 24 and 28 volts. If below this range, replace transformer.
	2. Insufficient supply voltage to the heat pump.	Check supply voltage to the heat pump. Supply voltage should be between 208 and 260 volts. Check to see if a phase is out. Should have 120 volts to ground and 240 volts across power legs.
HIGH REFRIG Alarm: Refrigerant high pressure switch is open.	1. Water circulation pump not on.	Verify water pump is on.
	2. Insufficient water flow.	Verify filter and skimmers are clean, backwash if necessary. Minimum flow 30 GPM.
	3. External bypass open.	Verify external water bypass around heat pump is closed. Also make sure all other valves are open or in the proper positions to allow proper water flow through heat pump.
	4. Bad refrigerant high pressure switch.	Check resistance of switch, if open, replace switch.
	5. TXV Stuck Closed.	1. Disconnect TXV bulb from suction line (SL), have it in your hand, if pressures go back to normal, then reinstall the bulb on suction line (it may have some debris stuck in the port). For adjustable TXVs open adjustable valve, it may remove the debris and set it back to original position. 2. If (1) does not work, recover the charge, remove bulb from SL, unscrew TXV head, shake it, if rattles, replace head (PN KT-45-ZGA), if not, replace TXV and filter dryer and charge appropriately.
	6. Other Possibilities:	Check Water level in pool. This condition may appear if the heat pump has NOT been operated for an extended period. To Clear this condition, cycle the heat pump on and off up to 3 times. If this does not correct problem, call for service.
	7. Other Possibilities. Low or restricted water flow through heater. Dirty or worn filters or clogged lint traps. Clogged filter pump impeller. Improper plumbing valve settings. Suction leak allowing air into the water flow. Low water flow when switched to spa mode. Unit is plumbed backwards. Heat exchanger clogged with debris. Internal bypass valve damaged or clogged with debris.	Clean entire filtering system and or replace filter element. Inspect & clean pump impeller. Adjust all plumbing valves. Repair suction air leaks, grease pump lid O-ring. Replace filter. Wrong filter pump pipe size. Automatic pool vacuum causing restriction. Call your dealer or factory for advice if above does not solve the problem.
	8. Unit overcharged.	Reclaim charge. Recharge with appropriate nameplate charge.
LOW REFRIG Alarm: Refrigerant low pressure switch is open.	1. Low refrigerant in system.	Find source of refrigerant leak and fix. Pull vacuum and recharge.
	2. Air and water temperatures too cold to operate the heat pump.	Wait until temperatures warm up and see if unit operates.
	3. Bad refrigerant low pressure switch.	Check resistance of switch with a full charge, if open, replace switch.
	4. Faulty fan blade.	Check the capacitor and fan motor. Replace either one if it is faulty. Check the fan blade and make sure it is not slipping or broken. If so, replace the fan.
	5. TXV Stuck Closed.	1. Disconnect TXV bulb from suction line (SL), have it in your hand, if pressures go back to normal, then reinstall the bulb on suction line (it may have some debris stuck in the port). For adjustable TXVs open adjustable valve, it may remove the debris and set it back to original position. 2. If (1) does not work, recover the charge, remove bulb from SL, unscrew TXV head, shake it, if rattles, replace head (PN KT-45-ZGA), if not, replace TXV and filter dryer and charge appropriately.
FIVE ALARMS: Indicates 5 faults have occurred in 1 hour. This fault will automatically reset in one hour or can be manually reset by pressing the ON/OFF button.	5 alarms of any kind within one hour.	Press the ON/OFF button to clear the alarm. Check Heat Pump over the next few minutes/hours to see if alarm appears again. This alarm most likely caused the five alarms in one hour.

Problem or Symptoms	Possible Cause	Corrective Action
Unable to turn Heat Pump ON. Display is Blank. Unit will NOT start.	Control failure. No power supply to heater. Tripped breaker or blown fuse. Faulty Transformer. Incorrect Wiring.	Reset breaker. Replace fuse. Call dealer or factory for advice before attempting to replace parts. Replace Transformer. Check wiring.
Unit power is ON and Set Temperature is above Actual. Unit will NOT start to heat or cool. No Alarms.	Remote feature enabled, but no controlling device hook-up. Control failure.	Check to see if the Remote feature on the Control Board is enable. Disable if needed. See Section 3 for more information on Remote function. Call dealer or factory for advice before attempting to replace parts. Replace Control Board.
Unit power is ON and Set Temperature is above Actual. Unit will NOT start to heat. No Alarms.	Heat Pump pool/spa selection mode incorrect. The thermostat is malfunctioning. Control Board Failure.	Check to see if heat pump is in correct active pool/spa mode by pressing the pool/spa button. If active mode is spa, but trying to heat/cool pool press pool/spa button again to change the active mode to pool. If active mode is Pool, but want spa heat change active mode to spa. Call dealer or factory for advice before attempting to replace parts. Replace thermostat. Replace Control Board.
Unit power is ON, and Set Temperature is above Actual. Unit cycles on and off, i.e. Compressor cuts on briefly and then off after Five minute delay before set point is reached.	Faulty Compressor. Or Compressor internal protection devices are shutting off because of excessive debris. Faulty Compressor contactor. Incorrect wiring. Control Board Failure. Internal bypass valve damaged or clogged with debris. Heat exchanger clogged with debris. Suction leak allowing air into the water flow. Unit is plumbed backwards.	Clean entire filtering system and or replace filter element. Inspect & clean pump impeller. Adjust all plumbing valves. Repair suction air leaks, grease pump lid O-ring. Replace filter. Wrong filter pump pipe size. Automatic pool vacuum causing restriction. Call your dealer or factory for advice if corrective action does not solve the problem. Possible Compressor's internal relief valve or overload protection device is faulty. Call dealer or factory for advice before attempting to replace parts. Replace Compressor.
Unit is forming ICE or Frost on the outer air coil, usually at the bottom.	Discharge air flow is restricted. Discharge air is accumulating and being drawn back through the outer air coil. The fan is obstructed, low air flow. Sprinklers spraying on the outer air coil during cooler temperatures. Outer air coil clogged with debris. Plants too close to heater, blocking discharge air flow. Low refrigerant pressure caused by a Refrigerant leak. Possible malfunctioning of the internal low refrigerant pressure switch. Check Alarm Status on Control Board for LOW REFRIG Alarm.	The outside air temperature too low and Defrost feature is NOT enable. Malfunctioning Defrost Thermistor. Make sure heater is installed with the required placement clearances for air flow and roof clearance. Do NOT install indoors. Make sure that your sprinklers do NOT spray on the heater in any way what so ever. If ice forms on the outer coil, shut the heater off and allow ice to thaw. You may use water at low pressure to thaw ice build up on the outer coil, shut the heater off when doing so. Call your dealer or factory for advice corrective action does not solve the problem.
Unit power is ON, and Set Temperature is above Actual. Fan is NOT Turning. No Alarms.	Faulty Fan Relay. Faulty Capacitor. Faulty Fan Motor. Control Board Failure. Incorrect wiring.	Call dealer for advice before attempting to replace parts. Replace Fan relay. Replace Capacitor, Replace Fan motor. Replace Control Board.
Fan is turning, no cool air discharge out of top of heater. Unit ON, and Set Temperature is above Actual, but Unit is not heating. No Alarms.	Heat Pump is in the five minute safety delay and Compressor has not started. Faulty Compressor. Faulty Capacitor. Compressor contactor is stuck open. Control Board failure. Incorrect wiring.	Call dealer or factory for advice before attempting to replace parts. Replace Capacitor. Replace Control board. Replace Contactor. Replace Compressor.
"Spa will not heat to maximum temperature of 104° F. Thermostat is turned all the way up. OR Spa is heating very slowly."	Low or restricted water flow through heater. Dirty or worn filters or clogged lint traps. Clogged filter pump impeller. Improper plumbing valve settings. Suction leak allowing air into the water flow. Low water flow when switched to spa mode or the control is not in spa mode. Unit is plumbed backwards. Heat exchanger clogged with debris. Internal bypass valve damaged or clogged with debris. Your spa thermometer is not reading the correct temperature. Air blower is running. Venturi air inlets are open. It is very cold outside. Spa pump is not running.	Clean entire filtering system and or replace filter element. Inspect & clean pump impeller. Adjust all plumbing valves. Repair suction air leaks, grease pump lid O-ring. Shut off air blower and or Venturi inlets that allow air turbulence in the spa. Use a cover while heating the spa. Outside air temp. too cold. Set spa pump timer for longer time. Call your dealer for advice. Call the factory for advice.
"Pool is heating very slowly. Pool is not getting up to temperature."	"Low or restricted water flow through heater. Dirty or worn filters or clogged lint traps. Clogged filter pump impeller. Improper plumbing valve settings. Suction leak allowing air into the water flow. It is cold outside. Pool pump timer is not set for a long enough running period. Pool is not covered. High wind speed over pool. Shaded pool area."	Clean entire filtering system and or replace filter element. Inspect & clean pump impeller. Adjust all plumbing valves. Repair suction air leaks, grease pump lid O-ring. Use a pool cover. Place a wind break around pool. Set pool pump timer longer. Call your dealer for advice. Call the factory for advice.

Problem or Symptoms	Possible Cause	Corrective Action
Higher than Normal Head Pressure, lower than normal suction pressure with high superheat and very cold or frosty distributor tubes, may have no Alarm	TXV stuck closed.	1. Disconnect TXV bulb from suction line (SL), have it in your hand, if pressures go back to normal, then reinstall the bulb on suction line (it may have some debris stuck in the port). For adjustable TXVs open adjustable valve, it may remove the debris and set it back to original position. 2. If (1) does not work, recover the charge, remove bulb from SL, unscrew TXV head, shake it, if rattles, replace head (PN KT-45-ZGA), if not, replace TXV and filter dryer and charge appropriately.
Lower than Normal Head Pressure, higher than normal suction pressure with cold suction line and compressor and no superheat, may have no Alarm.	TXV stuck open.	1. Check to see if TXV bulb is firmly attached to suction line, if loose, attach firmly by tightening the clamp over the bulb and suction line. 2. If (1) above does not work, reclaim charge and replace TXV and filter dryer with nameplate charge.
Unusually higher than normal current.	TXV stuck closed/partially closed, insufficient water flow, system overcharged.	See Possible Cause column for: TXV stuck closed, Insufficient water flow, and Unit overcharged.
Low current with high superheat.	Unit undercharged.	Find source of refrigerant leak and fix. Pull vacuum and charge.
Unit runs, but trips continuously.	Wires not connected properly.	Fix the miswire as per the Wiring Diagrams.

Problems and Corrective Action (3 Phase Units Only)

Problem or Symptoms	Possible Cause	Corrective Action
Unable to turn Heat Pump ON. Display is Blank. Unit will NOT start.	Incorrect Wiring.	Check the Light on Phase Monitor inside the electrical box. If red, switch two of the Input wires. Any two of the three can be switched.
	Faulty Phase Monitor.	Call dealer or factory for advice before attempting to replace parts. Replace Phase Monitor.
	Loose wire on Phase Monitor, either from the supply input power or the output side.	Check the Light on Phase Monitor inside the electrical box. If the Light is Red, fix the supply power loose end. If the Light is Green, fix the output loose wire.
Compressor making a loud or unusual noise or sounds during operation. Fan is turning, no cool air discharge out of top of heater. Unit ON, and Set Temperature is above Actual, but Unit is not heating.	Compressor running Backwards. This usually happens if the compressor wire harness is disconnected for possible repair or replacement.	Switch any two of the three wires on the compressor side of the Contactor.

***Temperature Resistance Chart**

°F	OHMS	°F	OHMS	°F	OHMS	°F	OHMS	°F	OHMS
0	85,387	51	19,377	66	13,136	81	9,076	96	6,382
10	62,479	52	18,870	67	12,809	82	8,861	97	6,238
20	46,225	53	18,377	68	12,491	83	8,651	98	6,097
30	34,561	54	17,899	69	12,182	84	8,447	99	5,960
40	26,100	55	17,435	70	11,882	85	8,249	100	5,827
41	25,391	56	16,985	71	11,589	86	8,056	101	5,697
42	24,704	57	16,548	72	11,305	87	7,867	102	5,570
43	24,037	58	16,123	73	11,029	88	7,684	103	5,446
44	23,391	59	15,711	74	10,761	89	7,506	104	5,326
45	22,764	60	15,310	75	10,500	90	7,333	105	5,208
46	22,156	61	14,921	76	10,246	91	7,164	106	5,094
47	21,566	62	14,543	77	9,999	92	6,999	107	4,982
48	20,993	63	14,176	78	9,758	93	6,839	108	4,873
49	20,438	64	13,820	79	9,525	94	6,683	110	4,664
50	19,900	65	13,473	80	9,297	95	6,530	120	3,758

The table below should be used by trained air-conditioning and refrigeration service people.

The table below **should not be used for adjusting the charge in the system.**

Use of interpolation or extrapolation of the table data may not be appropriate unless it is closely matched by the ambient and water flow conditions.

Air: 80F, 80%RH		Water: 80F, 45-50gpm	
Model	Discharge Pressure (psig)	Suction Pressure (psig)	Superheat (F)
HP500	359	134	14
HP700	348	132	14
HP900	355	142	10
HP1200	367	141	8
HP1200R	367	141	8
UltraTemp 90	340	147	20
UltraTemp 110	343	164	11
UltraTemp 120	350	157	9
UltraTemp 120 H/C	378	157	10
UltraTemp 120C	354	150	12
UltraTemp 100I	340	154	10
UltraTemp 90I	354	157	9
Air: 80F, 63%RH		Water: 80F, 45-50gpm	
Model	Discharge Pressure (psig)	Suction Pressure (psig)	Superheat (F)
HP500	352	125	11
HP700	341	123	11
HP900	348	132	8
HP1200	360	131	6
HP1200R	360	131	6
UltraTemp 90	330	138	18
UltraTemp 110	337	153	9
UltraTemp 120	344	146	7
UltraTemp 120 H/C	368	146	8
UltraTemp 120C	346	146	10
UltraTemp 100I	335	144	8
UltraTemp 90I	335	152	8
Air: 50F, 63%RH		Water: 80F, 45-50gpm	
Model	Discharge Pressure (psig)	Suction Pressure (psig)	Superheat (F)
HP500	330	83	5
HP700	320	81	4
HP900	325	85	4
HP1200	322	86	3
HP1200R	322	86	3
UltraTemp 90	312	93	4
UltraTemp 110	324	92	4
UltraTemp 120	330	90	3
UltraTemp 120 H/C	336	90	3
UltraTemp 120C	318	89	4
UltraTemp 100I	329	86	4
UltraTemp 90I	327	90	4
Air: 80F, 63%RH		Water: 104F, 45-50gpm	
Model	Discharge Pressure (psig)	Suction Pressure (psig)	Superheat (F)
HP500	457	137	7
HP700	445	142	8
HP900	450	141	5
HP1200	478	135	6
HP1200R	478	135	6
UltraTemp 90	440	152	8
UltraTemp 110	453	159	5
UltraTemp 120	450	152	4
UltraTemp 120 H/C	474	152	4
UltraTemp 120C	450	150	7
UltraTemp 100I	452	151	4
UltraTemp 90I	473	150	6

RH = Relative Humidity

Section 6

Replacement Parts

UltraTemp® Illustrated Parts

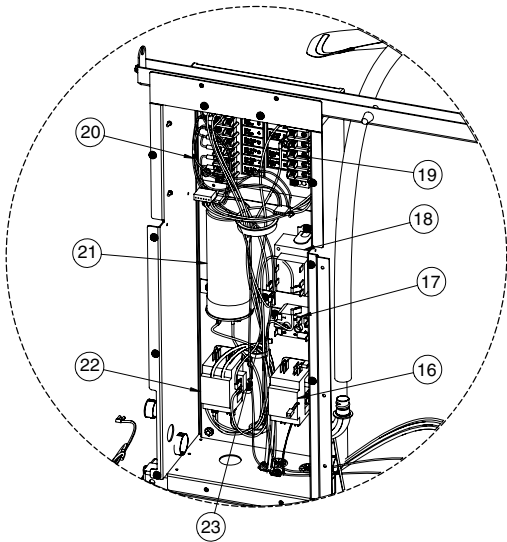

DETAIL B – Single Phase

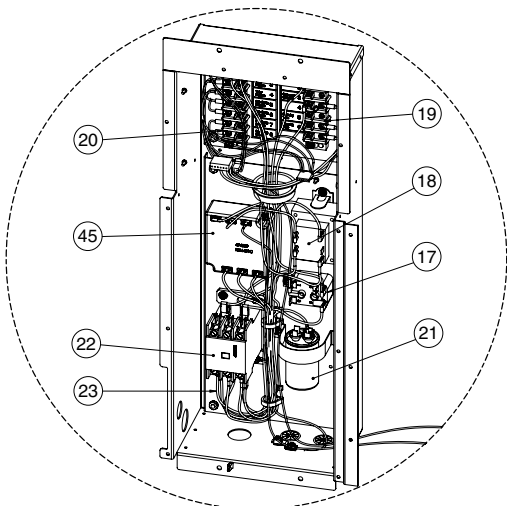

DETAIL B – Three Phase

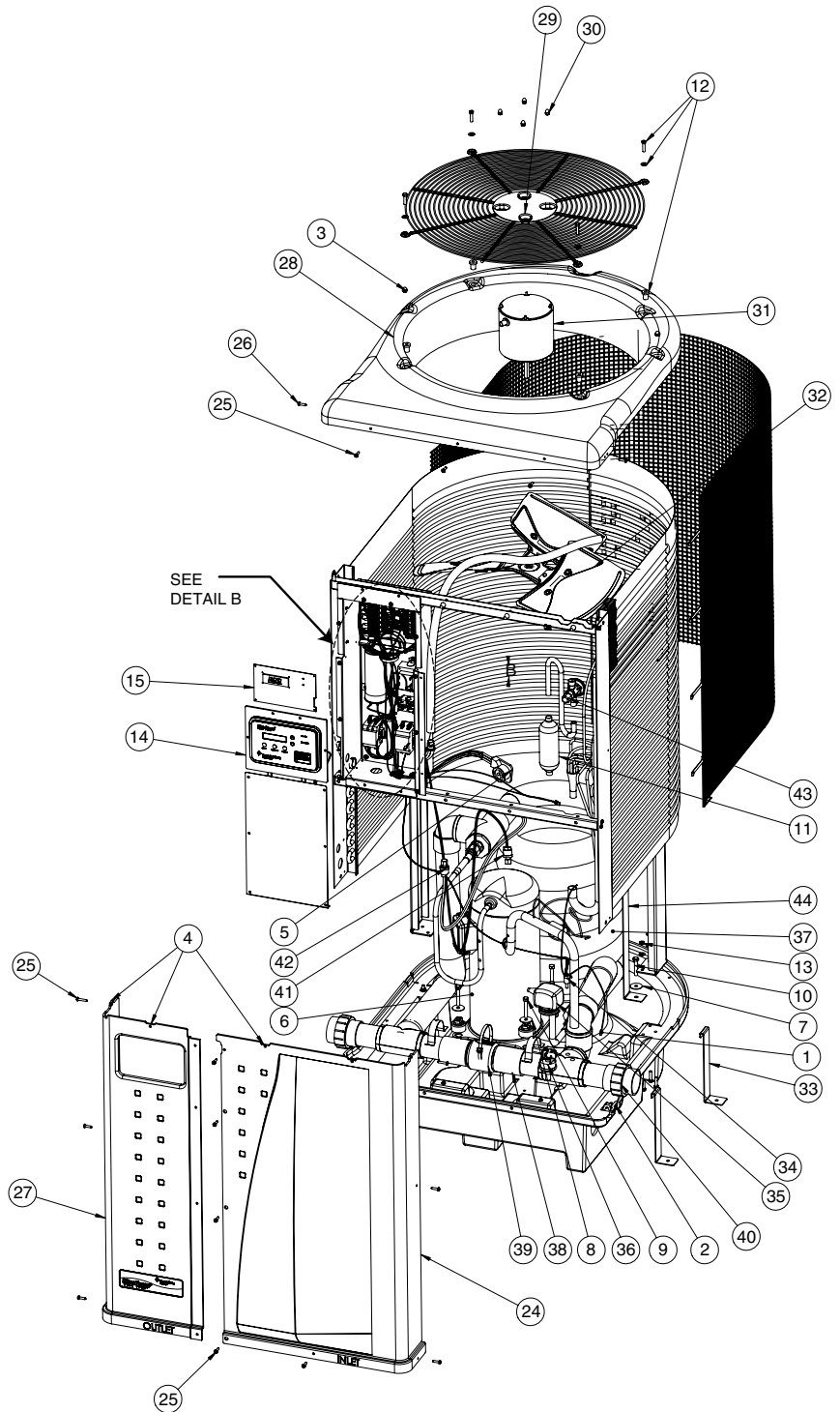

UltraTemp® Replacement Parts List

ITEM	PART NO.	DESCRIPTION
1	473665	Probe Thermister Defrost Sensor
2	470284	Nut, J-Clip
3	473285	Nut, 1/4 - 20 S/S Acorn
4	470281	Nut, U-Clip
5	473732	Wire Harness, Compressor (1PH-60Hz)
	474009	Wire Harness, Compressor (1PH-50Hz)
	474010	Wire Harness, Compressor (3-Phase Models)
6	473734Z	Compressor, Scroll ZP83 (Model 120, 120HC)
	473735Z	Compressor, Scroll ZP70 Model 110)
	474011Z	Compressor Kit, Scroll HLJ83 (3-Phase Model 120C only)
	473780Z	Compressor Scroll HLJ072 (Model 90I)
	474081Z	Compressor Scroll HLJ083 (Model 100I)
	474241Z	Compressor Scroll ZP61 (Model 90)
7	473295	Fender Washer
8	473736	Compressor Isolation Kit, Grommet and Spacer (1 Set)
9	473745	Bolt 5/16 - 18 x 1.75" S/S
10	98219800	Bolt 5/16 - 18 x 1" S/S
11	473121	Drier (Model 90, 110, 120, 120C, 100I, 90I)
	473139	Drier (Model 120HC)
12	470441	Fan Guard Fastener Kit
13	71406	Nut, 1/4 - 20 Hex S/S
14	473777	Bezel, Control Board w/ Label
15	473711	Auto Heat Control Board, High
16	473603	Pump Contactor AutoHeat
17	473150	Fan Relay
	474016	Fan Relay (3PH-50Hz only)
18	473155	Transformer
	473790	Transformer (3PH-50Hz only)
19	473422	Wire Harness Terminal Block - Fan, Compressor
20	473315	Wire Harness, Terminal Block - Sensors
21	473731	Capacitor (Model 90, 110, 120, 120 HC only)
	473154	Capacitor (3-Phase Model 120C only)
	470146	Capacitor (Model 100I)
22	473149	Contactora, Heat Pump (Model 90, 110, 120, 120HC, 100I)
	473778	Contactora, Heat Pump (3-Phase Models)
23	473423	Wire Harness, Main (Model 90, 110, 120, 120HC, 100I)
	474021	Wire Harness, Main (3-Phase Model 120C)
	474031	Wire Harness, Main (3-Phase Model 90I only)
24	473742	Panel, Front Right, 36" Almond
	474194	Panel, Front Right, 36" Black
	473431	Panel, Front Right (Model 100I only)
	473412	Panel, Front Right (Model 90I, 90)
	474265	Panel, Front Right (Model 90 Black)

ITEM	PART NO.	DESCRIPTION
25	470159	Screw #10 x .75" Pan Head Phillips, Almond
	470198	Screw #10 x .75" Pan Head Phillips, Black
26	470161	Screw #10 x 1" Button Head Torx, Almond
	474197	Screw #10 x 1" Button Head Torx, Black Head
27	473755	Panel, Front Left, w/ Decal, 36" Almond
	474196	Panel, Front Left, w/ Decal, 36" Black
	474202	Panel, Front Left, w/ Decal (Model 100I only)
	474203	Panel, Front Left, w/ Decal (Model 90I, 90)
28	474249	Panel, Front Left, w/ Decal, 24" Black
	473773	HP Top
29	474193	HP Top, Black
	473786	Guard, Fan
30	470439	Nut, #10-32 SS corn
31	473785	Fan Motor w/ Acorn Nut Kit
	474030Z	Fan Motor w/ Acorn Nut Kit (Model 90I only)
32	473783	Fan Blade (60Hz)
	474230	Fan Blade (50Hz)
33	470137	Tie Down Bracket
34	471566	Probe Thermister - Water Temperature
35	473606	Water Pressure Switch Boot
36	473605	Water Pressure Switch
37	473992	Titanium Heat Exchanger
	472736	Titanium Heat Exchanger (Model 100I, 90)
	472737	Titanium Heat Exchanger (Model 90I only)
38	473774	Water Bypass Manifold w/ 2 Street Elbows
39	R172305	Water Bypass Check Valve
40	473381	Union PVC 2"
41	473656	Switch, Low Pressure
42	473744	Switch, High Pressure
43	473787	Thermostatic Expansion Valve (Model 120, 120C, 90I)
	473999	Thermostatic Expansion Valve (Model 120HC, 110)
	474248	Thermostatic Expansion Valve (Model 100I)
	474242	Thermostatic Expansion Valve (Model 90)
44	473657	Titanium Water Coil Tie Down Strap (2 on Model 90I, 1 on Model 90, 100I)
	473772	Titanium Water Coil Tie Down Strap (1 on Models except 90I)
	473789	Titanium Water Coil Tie Down Strap (1 on Models except 90, 90I, 100I)
45	474089	Phase Monitor
-	473135	Reversing Valve (Model 120HC) [Not shown]
-	473432	Reversing Solenoid (Model 120HC) [Not shown] for Heat Cool Only
-	472734	Auto Set Board Bezel LBL Kit [Not shown]
-	474237	Clip Retension Comp. Pwr. [Not Shown]

NOTES

NOTES

SAVE THESE INSTRUCTIONS

